

# Classic Update Series

73-79 Ford F100-350 & 78-9 Ford Bronco

## START HERE !

PLEASE READ THIS BEFORE STARTING INSTALLATION !

This wiring kit is designed for ease of installation. Please read the guidelines below, BEFORE STARTING your installation to guarantee a successful job. Use an appropriate crimping tool which folds the wings of the open barrel terminals down into the wire as shown below. ALL TERMINALS THAT YOU INSTALL SHOULD BE PROPERLY SOLDERED. Our factory crimped terminations are installed by GM approved five ton presses, and soldering these terminations is not necessary. AAW offers a great terminal crimping video entitled "Proper Crimping Video". It can be viewed by using YouTube. Type the following address into your web browser to go directly to the video: [www.youtube.com/watch?v=8u\\_EkMsioMy](http://www.youtube.com/watch?v=8u_EkMsioMy).



### PLEASE READ THESE HELPFUL INSTALLATION TIPS BEFORE GOING ANY FURTHER!

Prior to installing the dash/main harness in your vehicle, plug all of the fuses, flashers, and horn relay (see a detailed description on page 11 of this instruction set) into the harness. Install the Dimmer, Headlight, Ignition and Wiper switches into their respective connectors on the harness assembly as well. These are all much easier to install onto the harness without the harness being installed in the vehicle. Once the switches and such have all been installed onto the harness, please use care when routing the assembly thru the vehicle as not to damage any of the switches by banging them into any metal supports or alike. See page 92970180, "1973-79 Fuse Panel Mounting Instructions", for some helpful hints on the installation and routing of the harness throughout the vehicle.

**AS THIS HARNESS IS DESIGNED FOR USE IN A MODIFIED TRUCK REQUIRING A HIGHER RATE OF CHARGE, IT DOES NOT SUPPORT THE USE OF A STOCK (ORIGINAL) ALTERNATOR. IT IS DESIGNED FOR USE WITH AN INTERNALLY REGULATED GM "SI" STYLE OR SINGLE WIRE STYLE ALTERNATOR. ADAPTERS (WHICH ARE NOT INCLUDED WITH THIS KIT) THAT ARE AVAILABLE FROM SEVERAL SOURCES WILL BE NECESSARY TO USE ANY ALTERNATOR OTHER THAN A GM "SI" STYLE OR SINGLE WIRE STYLE UNIT.**

#### STEP 1: DISCONNECT YOUR BATTERY:

Disconnect the battery before installing the wiring kit to prevent any accidental shorting caused by loose bare wire ends.

#### STEP 2: START INSTALLING KIT:

This kit is broken down into individual steps that are identified by a letter printed on the instruction sheets visible through each bag. These letters are the order of operation for installing your kit. Start with bag letter G, then H, etc. The order of installation is shown below. Use this main instruction sheet, 92970164, to complete the installation process.

- G - 510343 Dash Harness Kit
- H - 510344 Gauge Cluster Kit
- M - 510345 Rear Body Kit
- Z - 510476 Alternator and Main Connection Kit

#### STEP 3: RECONNECT YOUR BATTERY:

When you have completed the installation and are ready to reconnect the battery, make sure that the following electrical system grounds are in place:

- A. Battery is grounded to the ENGINE BLOCK.
- B. Battery is grounded to the frame.
- C. Engine block is grounded to the frame.
- D. Body is grounded to the frame.

#### STEP 4: CHECK ALL ELECTRICAL FUNCTIONS:

Any non-functioning items should be checked for proper installation. Any problems with your wiring and electrical circuit functions should be addressed to American Autowire Systems, Inc. as soon as possible to avoid any warranty problems.

If you have any questions concerning this or any of our products, please feel free to call us at 1-856-933-0801.

AMERICAN AUTOWIRE MAKES IT EASY !!

We carry many accessories for your 73-79 Ford Truck & 78-79 Bronco

p/n 510585  
OEM small terminal crimping  
tool (18-14 gauge)



p/n 510586  
OEM large terminal crimping  
tool (12-8 gauge)



p/n 510824  
Ford Duraspark  
Ignition Harness

p/n 510358  
78-79 Bronco Rear Power  
Window Harness



p/n 510359  
73-79 Dual Fuel Tank Harness

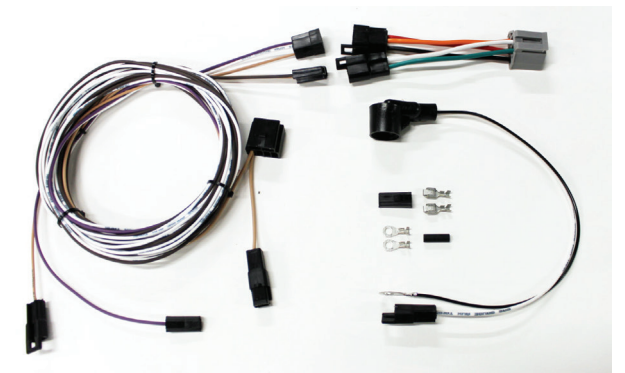

## American Autowire

[www.americanautowire.com](http://www.americanautowire.com) 856-933-0801

### Classic Update Series

1973-79 Ford F100-350  
& 1978-79 Ford Bronco

# 510342

© COPYRIGHT 2004 American Autowire / Factory-Fit  
Used with express permission of  
American Autowire / Factory-Fit

92970164 Rev. 16.0 JDM 05/20/2024

Fuse Box Assembly

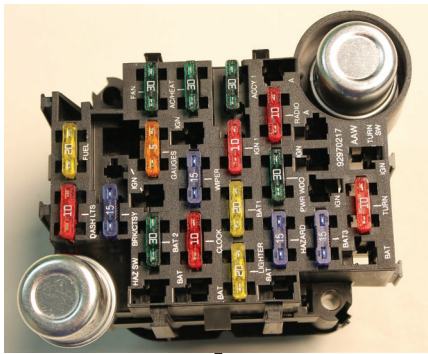

Please see page 11 of this instruction set for fuse and flasher locations

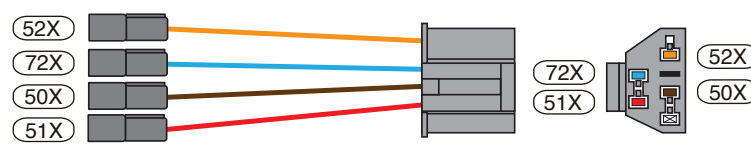
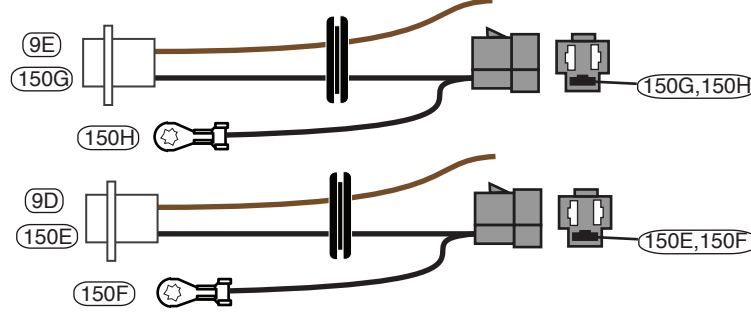
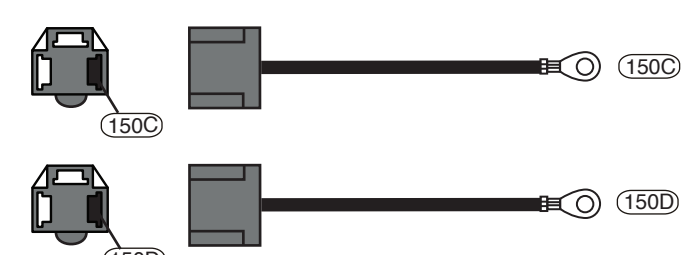
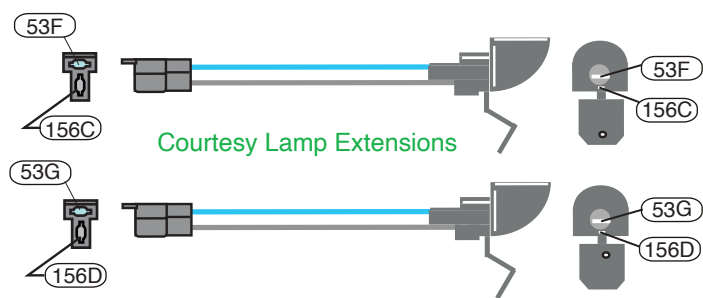
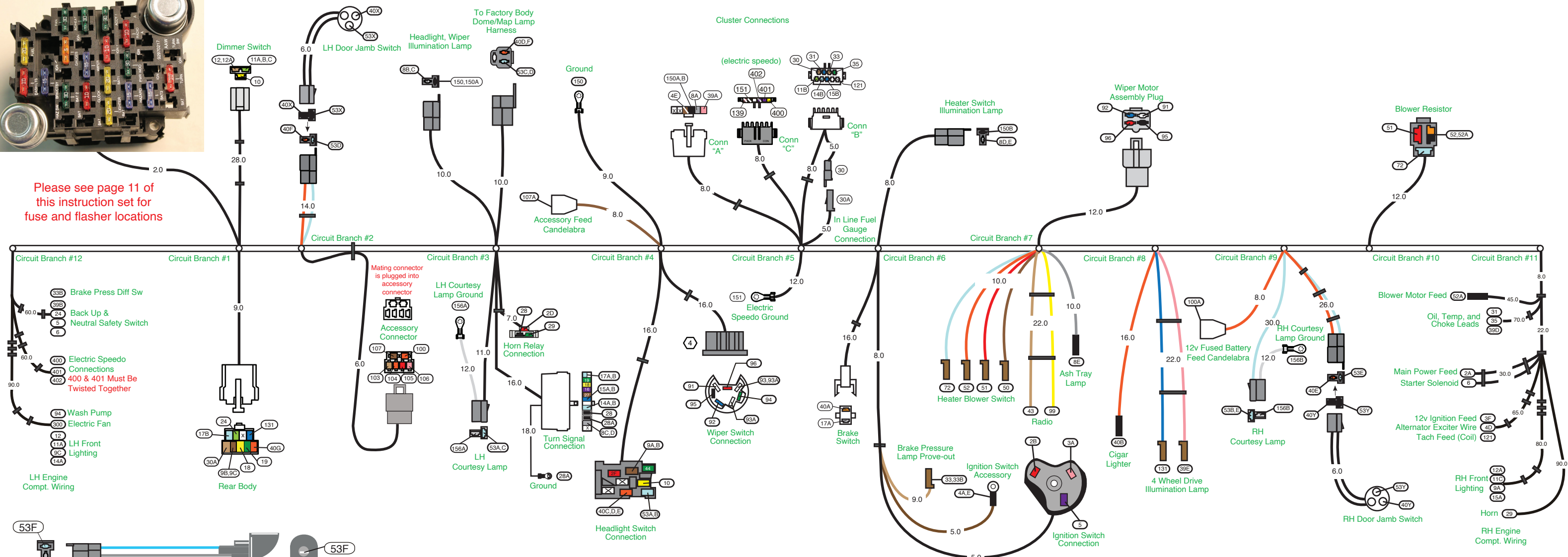

**NOTE:** Your new under dash courtesy lamp extensions use # 631 bulbs (not included with this kit). They may be purchased at any auto parts store.

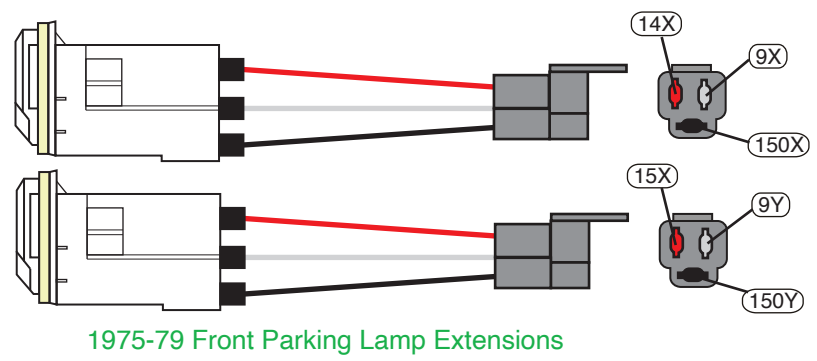

PART # **510342**  
 DESCRIPTION:  
**1973-79 Ford F100-350 & 1978-79 Ford Bronco Classic Update Series Kit**  
 92970164 Rev. 16.0 JDM 05/20/2024

Dash/Main Harness Installation Instructions

The fuse box on the Dash/Main harness is designed to be mounted under the dash to the LH side of the steering assembly just as the original did using the same two mounting holes as the original. See sheet 92970180 for a photo of the finish mounted fusebox. The enclosed representation of the main dash harness shows each circuit branch and identifies each connection by its color and function. Follow this drawing and the detail drawings on pages 10, 11 and 12 for individual circuit connections.

**Circuit Branch 12 - LH Front Lighting Connections** See page 12, Figure C for typical connections. For loose piece terminals and connectors, see parts kit # 510352.

**NOTE:** For the 1973-74 applications, you will need to re-use your existing original park/turn signal leads and sockets (not included in this kit) as they are part of the parking lamp assembly and are not serviced separately. We have provided you with terminals W and connector V to assemble onto your existing parking lamp leads so that you can connect them onto the new AAW wire leads 9C and 14A below coming from the dash/main harness 510343 to complete your LH parking and directional circuits. For the 1975-79 applications, you will use the provided 1975-79 parking lamp extensions as shown on page 2.

Wire #	Wire color	Printing	Procedure
14A	Light Blue	Left Front Turn	This wire should ultimately be mated with the high intensity filament (white with a lt. blue stripe wire) of the LH front parking lamp. Route to the left front parking lamp area, cut to length, install terminal B and plug into connector R in the location as shown on page 12, figure C. Be sure that this light blue wire mates to the stock white with lt. blue stripe wire (73-74) or the red wire in the 75-79 parking lamp extension.
9C	Brown	Park Lights	This wire should ultimately be mated with the low intensity filament (brown wire) of the LH front parking lamp. Route this brown wire to the left front parking lamp area, cut to length, double it with the brown wire coming from one of the front side marker extensions, install terminal C, and plug into the empty cavity in connector R that you just plugged the light blue wire into as shown on page 12 figure C. Route the side marker assembly thru the access hole in the inner fender and secure the grommet that is installed onto the side marker assembly into that access hole so that the side marker wiring is protected from chaffing. Take the black wire with the ring terminal that is part of the front side marker assembly and attach it to a good known chassis ground. You may now plug in your LF parking lamp extension from the <b>NOTE</b> above and that will complete your LF turn/parking lamp and LF side marker lamp circuits.
11A	Light Green	Headlight-Hi Beam	Select the light green Headlight Hi Beam wire (11A) and tan Headlight Low Beam wire (12). Route these wires to the LH headlight area, cut to length, install terminals A as found in kit 510352, and plug these wires into one of the front headlight extension assemblies (as shown on page 2) found on the dash/main wire kit, 510343. Take the black wire with the ring terminal that is part of the front headlight extension assembly and attach it to a good known chassis ground. Specific connection and orientation for this process can be found in the diagram on page 12, Figure C.
12	Tan	Headlight-Low Beam	

**Circuit Branch 12 - LH Engine Compt. Wiring** See page 12, Figures C and E for typical connections. For loose terminals and connectors, see parts kit # 510352.

Wire #	Wire color	Printing	Procedure
<b>Back Up and Neutral Safety Switch Connections</b>			
24	Lt. Green	Back Up Lt Sw	Route these wires to your neutral safety and back up lamp switch and connect them to the switch accordingly. If your truck has a manual transmission, connect the 5 and 6 wires together to complete the starter circuit. A typical aftermarket connection for your neutral safety and back up switch can be found on page 12, Figure E.
39B	Pink	12v Ign Fused	Switched feed from back up lamp switch to rear body connection.
5	Purple	Neutral Safety Sw	12v ignition feed to back up lamp switch.
6	Purple	Starter Solenoid	12v feed from solenoid post on the ignition switch to neutral safety switch.
			12v starter solenoid feed out from the neutral safety switch to the starter solenoid at branch 11.

**Electric Speedo Connections**

400	Yellow	VSS Ground	Connect to the Vehicle Speed Sensor ground lead.
401	Purple	VSS Signal	Connect to the Vehicle Speed Sensor signal lead.
402	Purple/White	VSS Power	Connect to the Vehicle Speed Sensor power lead if using a 3 wire sender.

**Electric fan Connection**

300	Orange	Electric Fan	This is the 12 volt ignition feed to connect to the trigger wire on your electric fan relay (relay not supplied with this kit).
-----	--------	--------------	---

**Windshield Washer Connection**

94	Dark Green	(no printing)	This is the 12v feed from the wiper switch inside the truck out to the washer pump assembly under the hood.
----	------------	---------------	---

**Brake Pressure Differential Switch**

**(NOTE:)** We have provided you with the connection to the original Ford brake warning switch in the form of a wire extension assembly (wires 33C, D on page 2 of this instruction sheet). You will plug this extension onto wire 33B, below.

33B	Tan	Brake Switch	Route this wire to the brake warning switch area near the master cylinder, cut to length, install terminal B, plug into connector E as shown on page 12, figure C, then plug this wire into wire extension assembly 33C, D (from page 2 of this instruction sheet) to complete your brake warning circuit.
-----	-----	--------------	--

**Circuit Branch 1 - Under dash Connections**

Wire #	Wire Color	Printing	Procedure
<b>Rear Body Connection</b>			
9B,C	Brown	Rear Running Lights/ Park Lights	This connector will plug into the Rear Body Kit, 510345. Specific connections are addressed in that kit. These wires will pass out to the engine bay through the LH driver's side firewall grommet as seen on page 12, Figure C. Feed out from headlight switch for the tail and license lamps and feed out to the LH front parking lamp.
17B	Lt. Blue	Third Brake Light	Feed from the brake lamp switch for optional 3rd brake lamp.
18	Yellow	Left Rear Turn	Feed out to the LH rear stop and turn lamp from the turn signal switch.
19	Dk. Green	Right Rear Turn	Feed out to the RH rear stop and turn lamp from the turn signal switch.
24	Lt. Green	Back Up Lt Sw	Feed out to the back up lamps (if so equipped) from the back up light switch.
30A	Tan	Gas Gauge	Main fuel tank sender signal wire between the rear body and cluster connections.
40G	Orange	12v Battery Fused	12v battery feed for LED lamps.
131	Dk. Blue	(no printing)	Ground circuit for 4wd dash illumination lamp out to switch at the transfer case.

**Fuse Box Assembly**

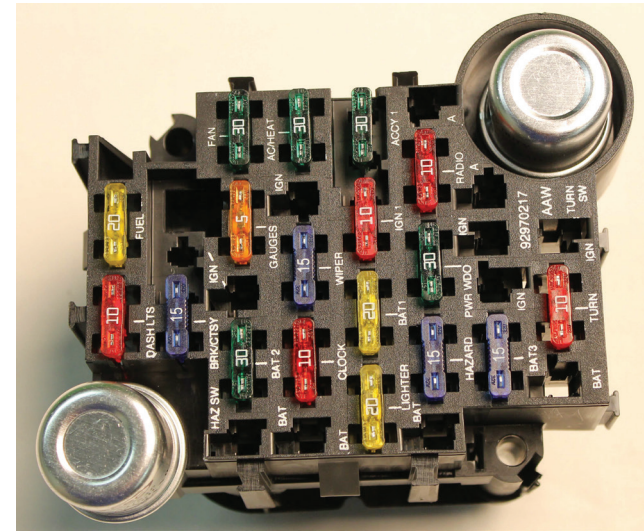

Please see page 11 of this instruction set for fuse and flasher locations

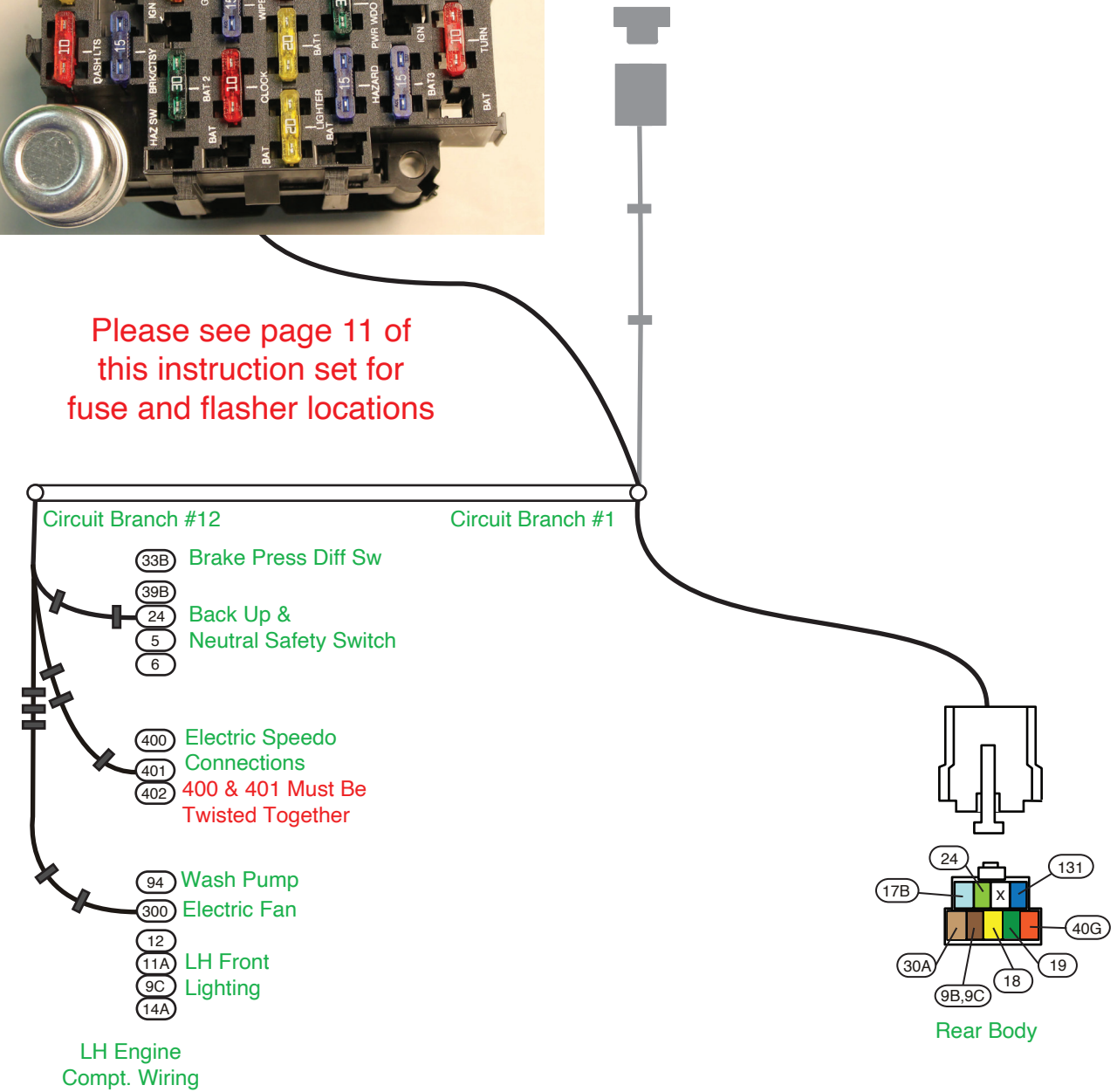

www.americanautowire.com 856-933-0801

PART # **510342**  
 DESCRIPTION:  
**1973-79 Ford F100-350  
 & 1978-79 Ford Bronco  
 Classic Update Series Kit**  
 92970164 Rev. 16.0 JDM 05/20/2024

**Circuit Branch 1 - Under dash Connections**

Wire # Wire Color Printing

Dimmer Switch		
10	Yellow	Dimmer Switch Feed
11A,B,C	Light Green	Headlight Hi Beam/ Hi Beam Indicator Light
12, 12A	Tan	Headlight Low Beam

Procedure

Plug this connector onto the new 500042 dimmer switch assembly.  
12v Feed from H/L switch.  
Switched 12v from dimmer to LH and RH high beam lamps, and to the dash cluster connector for the indicator lamp.  
Switched 12v from dimmer to LH and RH low beam lamps.

**Circuit Branch 2 - Under dash Connection**

Wire # Wire color Printing

LH Doorjamb Switch Connection		
40F,X	Orange	12v Bat Fused
53B,X	Lt. Blue	12v Ctsy Sw

Procedure

12 volt battery fused feed to the LH doorjamb switch.  
Switched 12 volt battery power for the dome lamp connection.  
**NOTE:** LH door jamb switch installation procedure. You have been provided with a new doorjamb switch and pigtail (40X and 53X black leads) on your new Dash/Main harness. To install them, remove the new switch from the wire harness pigtail. Next, slide the silicone rubber seal back down off of the switch connector and route the hard shell connector and the seal and wire pigtail thru the threaded hole in your doorjamb assembly. Once this portion of the pigtail assembly is thru the threaded hole, slide the seal back up over the hard shell connector, then plug the doorjamb switch back into the connector and seal assembly, then thread the new doorjamb switch into the threaded hole.

Accessory Wire Connector

Use the mating connector that is plugged into the dash harness along with the loose piece terminals that are provided in the dash loose piece kit (510343) to make your power connections (not included with this kit) for any of the following optional equipment:

Fuse	Rating	Description
BAT 3	20 amp	Fused 12 volt BATTERY feed for any needed battery fused accessory
FUEL	20 amp	Fused 12 volt IGNITION feed for fuel pump or fuel flow valve (or other fused ignition circuit)
BAT 2	30 amp	Fused 12 volt BATTERY feed for power seats (or another fused battery circuit)
BAT 1	20 amp	Fused 12 volt BATTERY feed for power door locks (or another fused battery circuit)
PWRWDO	30 amp	Fused 12 volt IGNITION feed for power windows (or another fused accessory circuit)
ACCY 1	30 amp	Fused 12 volt ACCESSORY feed (for any application)

**Circuit Branch 3 - Under dash Connections**

Wire # Wire color Printing

Dash Label Lamps		
8B,C	Gray	Dash Lights
150 & A	Black	Ground

Procedure

**NOTE:** These wires are used to illuminate the original headlight and wiper switch labels on the dash. **You will need to re-use your original lamp assembly.** Cut the original connector off of the stock lamp socket extension as close to the back of the connector as possible, install terminals B and plug into connector T from the 510352 kit. The original blue with red stripe wire will need to mate with the AAW gray "dash lights" wire, and the black wire will need to mate with the AAW black "ground" wire. Once you have installed the new terminals and connector onto your original lead wires, plug this connector into the mating connector on the AAW dash/main harness.

Factory Dome, Map, Cargo Lamp Connection

40D,F	Orange	12v Bat Fused
53C, D	Lt. Blue	12v Ctsy Sw

These wires will be used to mate to your stock dome, map, or cargo lamp circuits.

12 volt battery feed from the headlight switch to the map or cargo lamp circuits.

Switched 12 volt battery lead to dome lamp assembly.

**NOTE:** You will need to re-use your original factory Dome/Map/Cargo lamp wiring that routes up your windshield pillar and on over to the lamps. Cut off the factory 2-way brown connector that is on the end of the original factory harness (which can be found under the dash in the LH door jamb/cowl area), install terminals B and plug into connector R from the 510352 kit. The original black with blue stripe wire will need to mate with the AAW lt. blue "12v ctsy sw" wire, and the original green with yellow stripe wire will need to mate with the AAW orange "12v bat fused" wire. The third cavity will remain blank. Once you have installed the new terminals and connector onto your original lead wires, plug this connector into the mating connector on the AAW dash/main harness.

Horn Relay

2D	Red	12v Battery
28	Black	Horn Relay Ground
29	Dk. Green	Horn

Plug the horn relay (found in the 510353 fuse kit) into this connector.

12 volt battery feed.

Relay ground circuit (to steering column).

Triggered 12 volts to horn.

LH Courtesy Lamp Connection

53A,C	Lt. Blue	12v Ctsy Sw
156A	White	Ctsy Ground

Plug in 1 courtesy lamp extension (as found on page 2 of this instruction set) to complete this circuit.

Switched 12 volt battery power for LH under dash courtesy lamp and feed over to the dome/map lamp connector.

LH under dash courtesy ground. Attach the ring terminal to a good known chassis ground.

Turn Signal Switch Connection

Plug into steering column turn signal connection. If you are using a stock Ford steering column on your vehicle, you will need to cut off the existing Ford connector, and refer to Diagram 'A' and "Table A" - AAW turn signal wires to stock turn signal switch wires" on page 8, for proper mating directions. This kit is designed to function with a GM style turn signal switch. Our connector mates to a 3 7/8 inch long plug used on 1969-1974 GM, IDIDIT, many other aftermarket steering columns. Starting from 1975 on up, the GM switch changed and began using a 4 1/4 inch connector. That connector is from the same family and uses the same terminals. By using the supplied mating connector (L) and terminals (M) located in the loose piece kit bag of this dash harness (510343), it is easy to adapt any steering column to the kit. The function of the wires are as follows:

8C, D	Gray	Dash Lights	12v fused feed out from the fusebox for dash illumination lamps on transmission selector at steering column.
14A, B	Lt. Blue	Left Front Turn	LH front turn signal feed out to front light and dash cluster connections.
15A, B	Dk. Blue	Right Front Turn	RH front turn signal feed out to front light and dash cluster connections.
16	Purple	Turn Switch Feed	Turn signal 12v feed into column from flasher.
17A	Lt. Blue	Third Brake Lt.	12v feed for third brake light to rear body connector.
17B	White	Brake Sw	12v input from brake switch to turn switch for rear brake lights.
18	Yellow	Left Rear Turn	LH rear turn signal feed out to rear body connection.
19	Dk. Green	Right Rear Turn	RH rear turn signal feed out to rear body connection.
27	Brown	Turn Sw Hazard	Hazard switch 12v feed into column from flasher.
28	Black	Horn Relay Ground	Steering column horn ground to horn relay.
28A	Black	Horn Relay Ground	Steering column horn ground to horn relay. <b>Attach this wire to a good known chassis ground.</b>

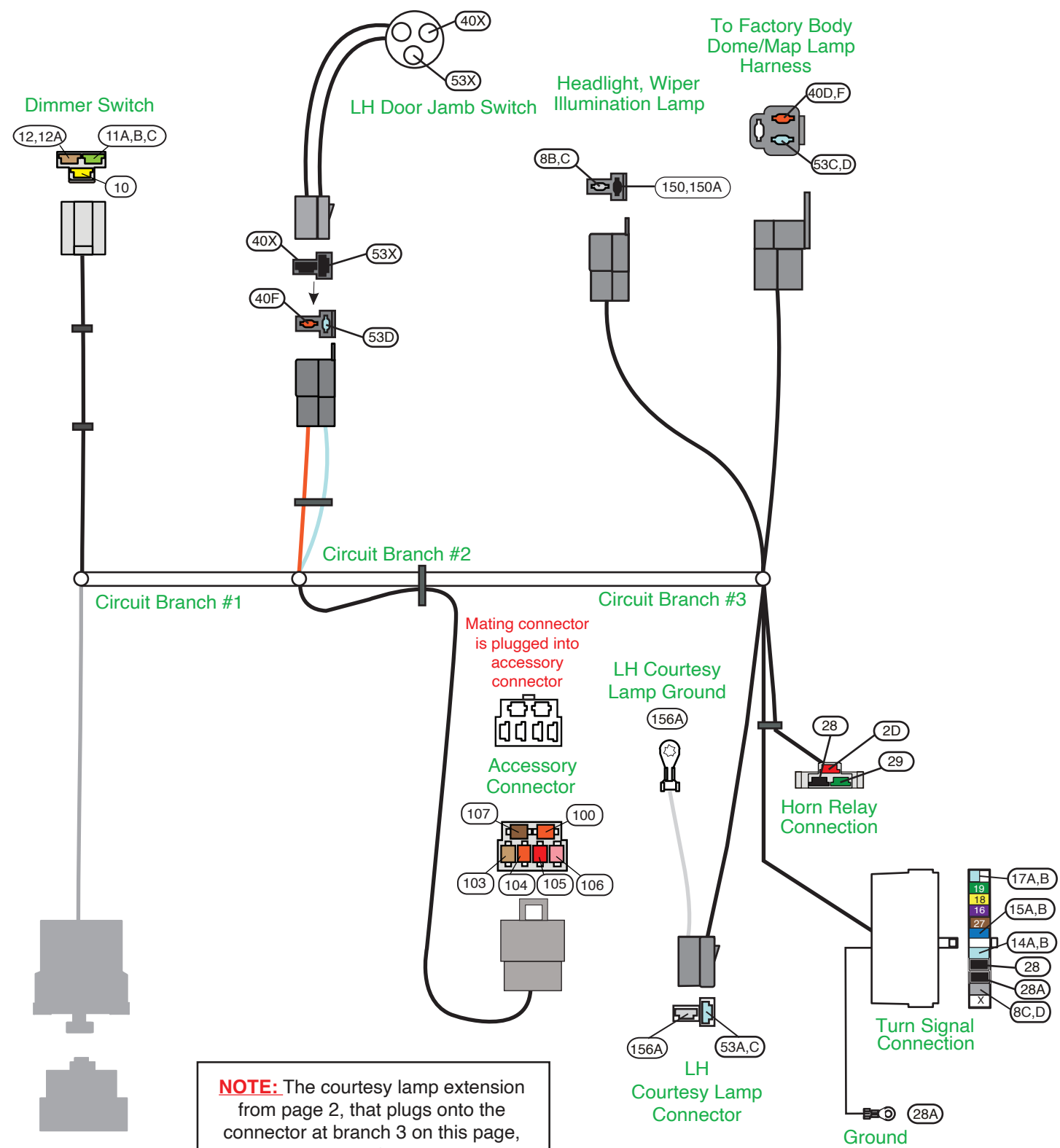

**NOTE:** The courtesy lamp extension from page 2, that plugs onto the connector at branch 3 on this page, uses a # 631 bulb (not included with this kit). They may be purchased at any auto parts store.

**American Autowire**  
www.americanautowire.com 856-933-0801

PART # **510342**  
DESCRIPTION:  
**1973-79 Ford F100-350 & 1978-79 Ford Bronco Classic Update Series Kit**  
92970164 Rev. 16.0 JDM 05/20/2024

Procedure

**Circuit Branch 4 - Under dash Connections**

Wire #	Wire Color	Printing
--------	------------	----------

Ground Lead		
150	Black	Ground
Accessory Feed Candelabra		
107A	Brown	(no printing)

Lighting Switch		
2F	Red	12v Battery
9A, B	Brown	Park Lights/ Rear Running Lights
10	Yellow	Dimmer Sw Feed
40C,D,E	Orange	12v Battery Fused
44	Dk. Green	(no printing)
53A, B	Lt. Blue	12v Ctsy Sw

Wiper Switch		
93, 93A	White	Wiper Feed
93A	White	Wiper Feed
91	White	(no printing)
92	Dk. Blue	(no printing)
94	Dk. Green	(no printing)
95	Black	(no printing)
96	Red	(no printing)

**Circuit Branch 5 - Under dash Connections**

Wire #	Wire color	Printing
--------	------------	----------

Ground Lead		
151	Black/White	Speedo Ground

Instrument Cluster Connections

Connector A		
4E	Brown/White	(no printing)
8A	Gray	Dash Lights
39A	Pink	12v Ign Fused
150A,B	Black	Ground

Connector B		
11B	Lt. Green	Hi Beam Indicator Light
14B	Lt. Blue	Left Turn Ind
15B	Dk. Blue	Right Turn Ind
30	Tan	Gas Gauge
31	Dk. Blue	Oil Pressure
33	Tan	Brake Light/Switch
35	Dk. Green	Water Temp Sender
121	White	Coil Tach

Connector C		
139	Pink/White	Speedo Power
151	Black	Ground
400	Yellow	VSS Ground
401	Purple	VSS Signal
402	Purple/White	VSS Power

In-Line Fuel Gauge Connection

30A	Tan	tan "gas gauge" wire connector Gas Gauge
-----	-----	---

**Circuit Branch 6 - Under dash Connections**

Wire #	Wire color	Printing
--------	------------	----------

Ignition Switch Connector		
2B	Red	12v Battery
3A	Pink	Ignition Feed
5	Purple	Neutral Safety Switch
Ignition Switch Accessory Ring Terminal		

4A, E	Brown	Ignition Sw Accessory/ Brn/White (no printing)
Ignition Switch Single Brown Connector		

33, 33B	Tan	Brake Light/Switch
---------	-----	--------------------

Procedure

Attach this wire to a good known chassis ground. (Note: Do not attach this wire with the 151 wire at branch 5)  
Chassis ground for instrument cluster and dash label lamp connections.

12v fused accessory feed connection. This 3 way connector can be used to plug in various accessories.

Plug this connector onto lighting switch 510264.  
Unfused 12v battery feed to the lighting switch for headlamps, tail lamps, and dash illumination lamps.  
Feed out to RH front parking and rear tail lamps at the rear body connector.

Feed to headlight dimmer switch for headlights.  
Secondary fused 12v battery feed to lighting switch from fusebox to RH door jamb and map/cargo lamp switches.  
Feed out from H/L switch to fusebox for dash lamps.  
Switched 12 volt battery power from lighting switch to dome and under dash courtesy lamps.

Plug this connector onto the new 510346 wiper switch assembly.

12v fused feed for wiper switch assembly.  
12v fused feed for washer pump lead.  
Switched 12v lead out for wiper low speed.  
Switched 12v lead out for wiper high speed.  
Switched 12v lead out for washer pump.  
Wiper motor park.  
Wiper motor low park.

Procedure

Attach this wire to a good known chassis ground. (Note: Do not attach this wire with the 150 wire at branch 4)  
Chassis ground for instrument cluster electric speedo connection.

These connections will plug into the Cluster Connection Kit, 510344. Specific connections are addressed in that kit.

Resistance feed from accessory on the ignition switch to the cluster for use with stock gauges.  
12v fused feed out from the fusebox for dash illumination lamps to cluster connection.  
Fused 12v Ignition feed to cluster connection for any aftermarket 12v gauges or stock warning lamps.  
Gauge cluster ground to cluster connection.

12v feed to dash cluster for high beam indicator lamp to cluster connection.  
12v feed to dash cluster for left front turn indicator lamp to cluster connection.  
12v feed to dash cluster for right front turn indicator lamp to cluster connection.  
In-line fuel sender signal to cluster connection.  
Oil pressure signal from engine lead to cluster connection.  
Ground for brake warning lamp to cluster connection.  
Temperature sender signal from engine lead to cluster connection.  
Tach sender signal wire from engine lead to the cluster connection.

Fused 12v Ignition feed for electric speedometer to cluster connection.  
Electric speedometer ground to cluster connection.  
VSS ground from engine leads to cluster connections for electric speedometer.  
VSS signal from engine leads to cluster connections for electric speedometer.  
VSS 12v fused power from cluster connections to engine leads for electric speedometer.

Plug this connector (30A) into the in-line #30 tan "gas gauge" wire and connector coming from the dash cluster connector B above if your truck has a single fuel tank. If your truck has dual fuel tanks, you will need to purchase the optional dual fuel tank harness P/N 510359. That harness will mate to this connector as well as the in-line #30 tan "gas gauge" wire connector that comes from the dash cluster connector B to complete the fuel gauge circuits.  
Gas gauge feed from the rear body connector.

Procedure

Plug this main connector onto the ignition switch 510053.

Battery feed to the ignition switch.  
Ignition feed to fuse panel and ignition system.  
Start feed to neutral safety switch.

After the ignition switch connector above is plugged onto the 510053 ignition switch, attach this ring terminal to the threaded accessory stud on the ignition switch using the nuts included with the switch.  
Accessory feed to fuse panel and accessory resistance wire to cluster connector A from ignition switch.

After the ignition switch connector and ring terminal above have been plugged onto the 510053 ignition switch, plug this connector onto the single exposed blade on the ignition switch. This connection is a ground and will provide a bulb check for the brake warning lamp when the ignition switch is in the cranking position.  
This connector plugs onto the ground blade on the 510053 ignition switch and is the bulb check ground for the brake warning circuit.

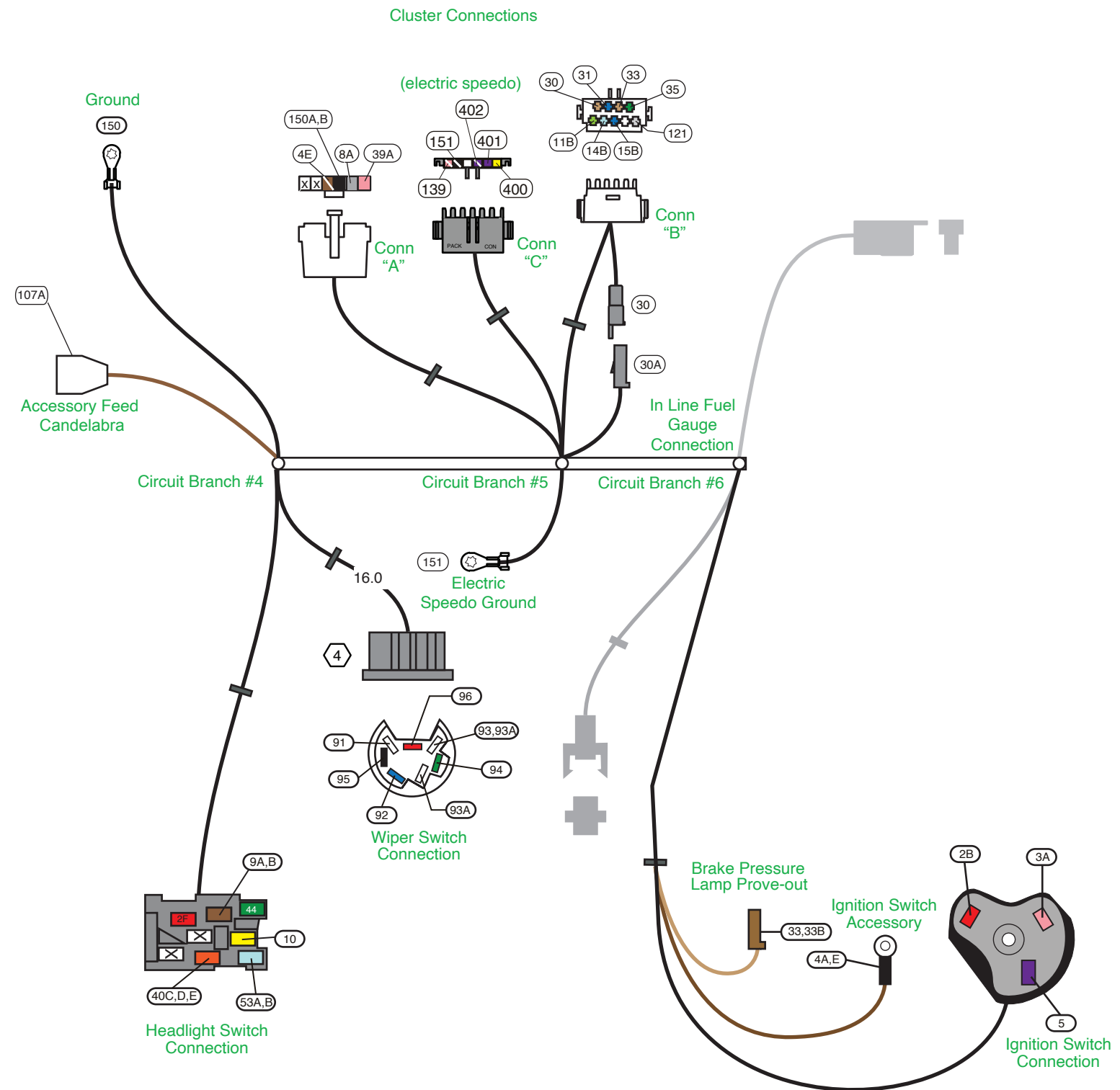

www.americanautowire.com 856-933-0801

PART # **510342**  
DESCRIPTION:  
**1973-79 Ford F100-350  
& 1978-79 Ford Bronco  
Classic Update Series Kit**

92970164 Rev. 16.0 JDM 05/20/2024

**Circuit Branch 6 - Under dash Connections**

Wire #	Wire Color	Printing	Procedure
<b>Dash Label Lamps</b>			
<b>NOTE:</b> These wires are used to illuminate the original heater switch label on the dash. <b>You will need to re-use your original lamp assembly.</b> Cut the original connector off of the stock lamp socket extension as close to the back of the connector as possible, install terminals B and plug into connector T from the 510352 kit. The original blue with red stripe wire will need to mate with the AAW gray "dash lights" wire, and the black wire will need to mate with the AAW black "ground" wire. Once you have installed the new terminals and connector onto your original lead wires, plug this connector into the mating connector on the AAW dash/main harness.			
8D,E	Gray	Dash Lights	12v fused feed out from the fusebox to dash label lamp connection.
150B	Black	Ground	Chassis ground for dash label lamp connections.

**Brake Switch Connections**

40A	Orange	12v Battery Fused	Plug this on to your stock brake lamp switch. Battery fused 12v feed to the brake switch.
17A	White	Brake Switch	12v feed out of the brake switch to the turn signal switch.

**Circuit Branch 7 - Under dash Connections**

Wire #	Wire Color	Printing	Procedure
<b>Wiper Motor Wire Leads</b>			
<b>NOTE:</b> The stock wiring connector on the factory Ford wiper motor pigtail will need to be replaced with the AAW 4-way female connector S (found in the 510352 parts kit). Cut the molded Ford connector containing the 4 wires (red, white, blue, and black) from the stock pigtail, install terminals B (found in the 510352 parts kit) and plug into connector S maintaining color continuity with the mating 4-way male connector found on the dash/main harness at branch 7.			
91	White	(no printing)	Switched 12v lead out for wiper low speed.
92	Dk. Blue	(no printing)	Switched 12v lead out for wiper high speed.
95	Black	(no printing)	Wiper motor park.
96	Red	(no printing)	Wiper motor low park.

**Heater Blower Switch Connection**

**NOTE:** For the 1973 through early 1978 (before serial number CA0001) built vehicles, connect the four 1-way brown connectors found on the dash/main harness containing the brown, red, orange, and light blue wires to the heater/blower switch as shown in Photo "A" on page 7. For late 1978 (after serial number CA0001) and all 1979 built vehicles, you will need to plug these wires into the 1978-79 Heater/Blower Switch Extension, found below to the right (and also on page 2) of this instruction set page. Please match these 1-way connectors, wire color for wire color. Once this is completed, you may plug the 1978-79 Heater/Blower Switch Extension onto your heater/blower switch.

50	Brown	Heater AC Feed	12v switched feed for "on/off" power to your stock heater switch or aftermarket heat and A/C.
51	Red	(no printing)	12v switched power to blower resistor for heater/blower low speed.
52	Orange	(no printing)	12v switched power to blower resistor for heater/blower high speed.
72	Lt. Blue	(no printing)	12v switched power to blower resistor for heater/blower medium speed.

**Radio Connections**

43	Tan	Radio	12v fused accessory feed for radio "on/off" power.
99	Yellow	Clock Battery	12v fused battery feed for radio clock and memory or dash clock assembly.

**Ashtray Lamp Connection**

8E	Gray	Dash Lights	Plug this lead onto your original ashtray lamp lead (not included with this kit). 12v fused feed out from the fusebox to ashtray lamp connection.
----	------	-------------	---

**Circuit Branch 8 - Under dash Connections**

Wire #	Wire Color	Printing	Procedure
<b>Cigarette Lighter</b>			
40B	Orange	(no printing)	Plug this connection onto your original lighter socket assembly (not included with this kit). 12v fused battery feed for the cigarette lighter.

**4wd Illumination Lamp**

39E	Pink	12v Ign Fused	12v ignition feed to 4wd indicator lamp.
131	Dk. Blue	(no printing)	Ground wire from 4wd indicator lamp down to transfer case.

**Circuit Branch 9 - Under dash Connections**

Wire #	Wire Color	Printing	Procedure
<b>Battery Feed Candelabra</b>			
100A	Orange	(no printing)	12v fused battery feed connection. This 3-way connector can be used to plug in various battery powered accessories.

**RH Courtesy Lamp Connection**

53B,E	Lt. Blue	12v Ctsy Sw	Plug in 1 courtesy lamp extension (as found on page 2 of this instruction set) to complete this circuit. Switched 12 volt battery power for RH under dash courtesy lamp and feed over to the RH door jamb switch connection.
156B	White	Ctsy Ground	RH under dash courtesy ground. Attach the ring terminal to a good known chassis ground.

**RH Doorjamb Switch Connection**

40E,Y	Orange	12v Bat Fused	12 volt battery fused feed to the RH doorjamb switch.
53E,Y	Lt. Blue	12v Ctsy Sw	Switched 12 volt battery power to the RH doorjamb switch from the RH courtesy lamp connection.

**NOTE:** RH door jamb switch installation procedure. You have been provided with a new doorjamb switch and pigtail (40Y and 53Y black leads) on your new Dash/Main harness. To install them, remove the new switch from the wire harness pigtail. Next, slide the silicone rubber seal back down off of the switch connector and route the hard shell connector and the seal and wire pigtail thru the threaded hole in your doorjamb assembly. Once this portion of the pigtail assembly is thru the threaded hole, slide the seal back up over the hard shell connector, then plug the doorjamb switch back into the connector and seal assembly, then thread the new doorjamb switch into the threaded hole.

**Circuit Branch 10 - Under dash Connections**

**Blower Motor Resistor Connector**

51	Red	(no printing)	Plug this connector onto the blower motor resistor on your heater box (stock heater vehicles ONLY). 12v switched power to blower resistor from the blower switch for heater/blower low speed.
52	Orange	(no printing)	12v switched power to blower resistor from the blower switch for heater/blower high speed.
52A	Black	(no printing)	Feed out from the blower resistor to the blower motor.
72	Lt. Blue	(no printing)	12v switched power to blower resistor from the blower switch for heater/blower medium speed.

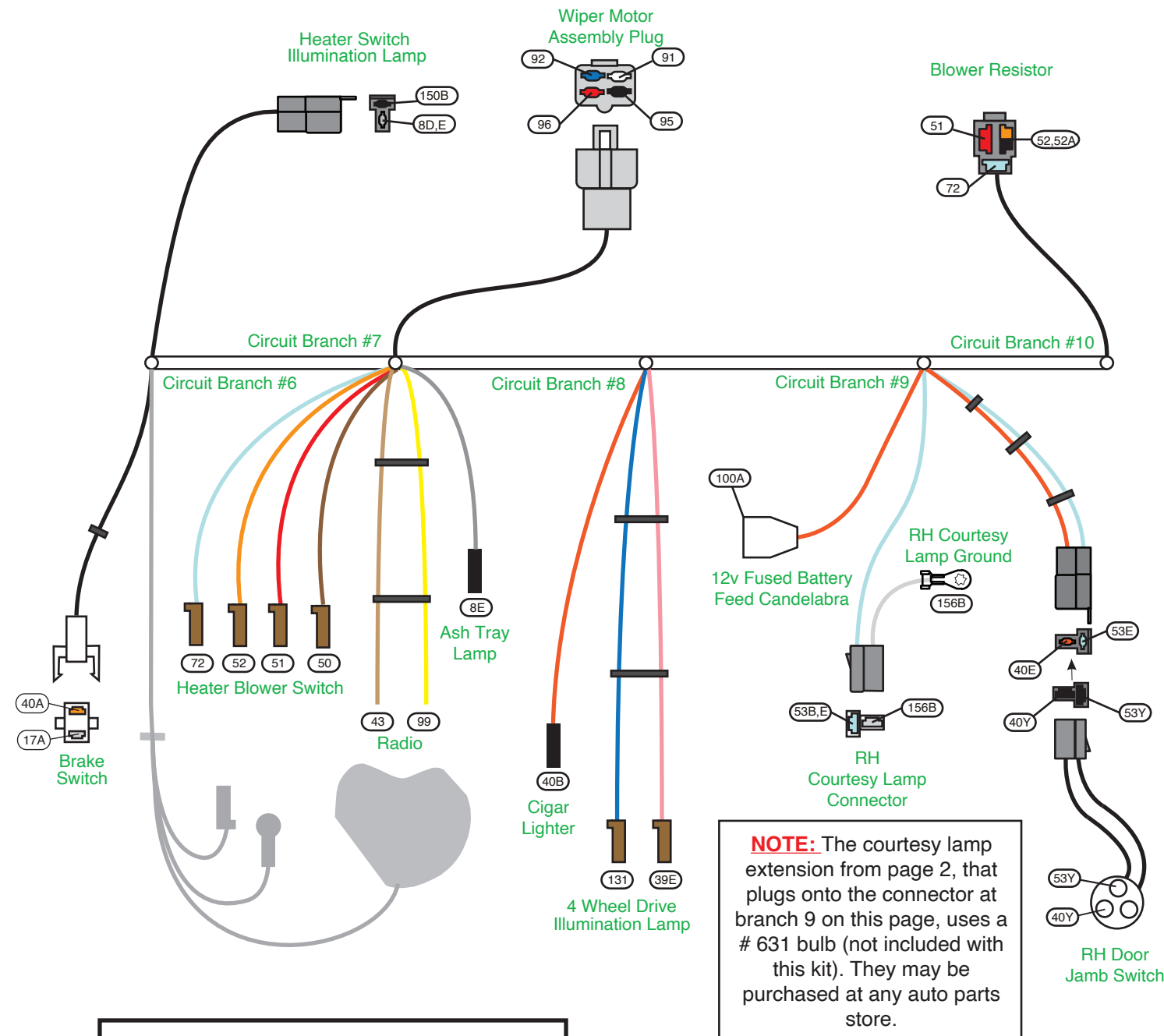

See page 7, Photo "A" for proper connector plug-in and orientation of Heater Blower Switch 50, 51, 52, and 72 wires (from above).

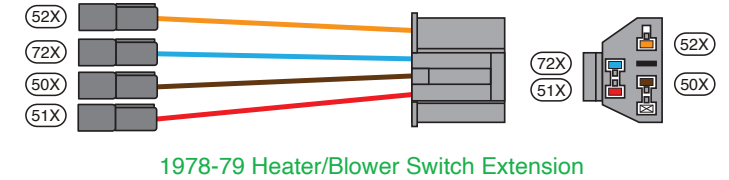

**American Autowire**  
www.americanautowire.com 856-933-0801

PART # **510342**  
DESCRIPTION:  
**1973-79 Ford F100-350 & 1978-79 Ford Bronco Classic Update Series Kit**  
92970164 Rev. 16.0 JDM 05/20/2024

**Circuit Branch 11 - RH Front Lighting Connections**

See page 10, Figure A for typical connections. For loose piece terminals and connectors, see parts kit # 510352.

**NOTE:** For the 1973-74 applications, you will need to re-use your existing original park/turn signal leads and sockets (not included in this kit) as they are part of the parking lamp assembly and are not serviced separately. We have provided you with terminals W and connector V to assemble onto your existing parking lamp leads so that you can connect them onto the new AAW wire leads 9A and 15A below coming from the dash/main harness 510343 to complete your RH parking and directional circuits. For the 1975-79 applications, you will use the provided 1975-79 parking lamp extensions as shown on page 2.

Wire #	Wire color	Printing	Procedure
15A	Dark Blue	Right Front Turn	This wire should ultimately be mated with the high intensity filament (white with a lt. blue stripe wire) of the RH front parking lamp. Route this dk. blue wire to the right front parking lamp area, cut to length, install terminal B and plug into connector R in the location as shown on page 10, figure A. Be sure that this dark blue wire mates to the stock white with lt. blue stripe wire (73-74) or the red wire in the 75-79 parking lamp extension.
9A	Brown	Park Lights	This wire should ultimately be mated with the low intensity filament (brown wire) of the RH front parking lamp. Route this brown wire to the right front parking lamp area, cut to length, double it with the brown wire coming from the other front side marker extension, install terminal C, and plug into the empty cavity in connector R that you just plugged the dark blue wire into as shown on page 10, figure A. Route the side marker assembly thru the access hole in the inner fender and secure the grommet that is installed onto the side marker assembly into that access hole so that the side marker wiring is protected from chaffing. Take the black wire with the ring terminal that is part of the front side marker assembly and attach it to a good known chassis ground. You may now plug in your RF parking lamp extension from the NOTE above and that will complete your RF turn/parking lamp and RF side marker lamp circuits.
11C	Light Green	Headlight-Hi Beam	Select the light green Headlight Hi Beam wire (11C) and tan Headlight Low Beam wire (12A). Route these wires to the RH headlight area, cut to length, install terminals A as found in kit 510352, and plug these wires into the other front headlight extension assembly (as shown on page 2) found on the dash/main wire kit, 510343. Take the black wire with the ring terminal that is part of the front headlight extension assembly and attach it to a good known chassis ground. Specific connection and orientation for this process can be found in the diagram on page 10, Figure A.
12A	Tan	Headlight-Low Beam	

**Circuit Branch 11 - Eng., Alt. & Power connections**

See pages 10, 11, and 12, Figures A and D for typical connections. For loose terminals/connectors, see parts kit # 510352.

Wire #	Wire color	Printing	Procedure
6	Purple	Starter Solenoid-S	Connect the end that comes out with the heavy red power wire 2A to the "S" terminal on your starter solenoid as shown on page 10, figure A.
2A	Red	12 V Battery	Route the red 12V Battery wire (circuit 2A) which is in the Dash Harness, to the Mega Fuses (see Figure D on page 12) and cut to length. Use ring terminal and shrink tubing from 510476 kit. Connect as shown on page 12.
2	Red	(no printing)	Use the 6ga red wire, Mega Fuse, boot, ring terminals, and shrink tube from the 510476 kit. Route from the Mega Fuse to the alternator cut to length and apply ring terminals, shrink tube, boot then connect per the instructions in the 510476 Alternator and Main Power Connection kit.
2G	Red	(no printing)	GM style "SI" alternator connector. See the connection instructions on page 12, figure D.
4D	Brown	Alternator Ign	<b>NOTE: If you are using a one-wire alternator, the 4D wire below will not be used, so tape it back to the trunk of the harness as it has 12v accessory voltage on it.</b> This wire is the exciter wire for your alternator / voltage regulator. It DOES NOT have any resistance on it as most stock exciter feeds do. If this wire is used, an in-line diode or resistor (not included with this kit) will be required between this wire and the alternator plug-in (wire 2J) to eliminate "run on" when the vehicle is switched off.
3F	Pink	Ignition Feed - coil	This is your 12 volt switched power source for the distributor/coil. This can be connected directly to the "bat" terminal on a typical HEI distributor, to a ballast resistor as in a points type distributor, or be used as the ignition power source for an aftermarket ignition module such as an MSD or "Duraspark" module. See the installation instructions for the type of distributor you are using for specific connection requirements. If you are using a GM style HEI distributor, terminal C and connector P have been provided to make that connection (See page 11 for some examples).
121	White	Coil - Tach	This can be connected directly to the tach terminal on a typical HEI distributor, to the negative side of the coil, or a tach connection in an aftermarket ignition module such as an MSD module. If you are using a GM style HEI distributor, terminal B and connector Q have been provided to make that connection (See page 9, Figure A for some examples).
31	Dark Blue	Oil Pressure Sender	Connect to the oil pressure sender (See page 10, figure A for some examples).
35	Dark Green	Water Temp Sender	Connect to the temperature sender (See page 10, figure A for some examples).
39D	Tan	Electric Choke	On carbureted vehicles, connect to the electric choke terminal (no mating terminals or connectors have been provided to make this connection).

Wire #	Wire color	Printing	Procedure
29	Dark Green	Horn	Route this wire to the RH horn, cut to length. If you have one horn, install terminal B and plug into connector N as shown on page 10, figure A. If you have 2 horns, double that wire with the cutoff portion, install terminal C and plug into connector N as shown on page 10, figure A. Route the loose end of that wire over to the LH horn, cut to length, install terminal B and plug into connector N as shown on page 10, figure A. Plug these completed wire connections onto your horns to complete your horn circuit(s).

Wire #	Wire color	Printing	Procedure
52A	Black	(no printing)	If your truck is a stock heater only vehicle, plug this wire directly onto your factory original blower motor pigtail lead. For some later applications, the factory original blower motor pigtail may have a blade style terminal (or female bullet terminal just as this AAW blower motor lead has). In those instances, simply cut the terminal off of your stock pigtail lead, install sleeve J and terminal U onto your original wire, then slide sleeve J back up over terminal U. Once this is completed, you will be able to plug your original lead onto the new AAW blower motor wire.



GM "SI" Alternator Exciter Wiring

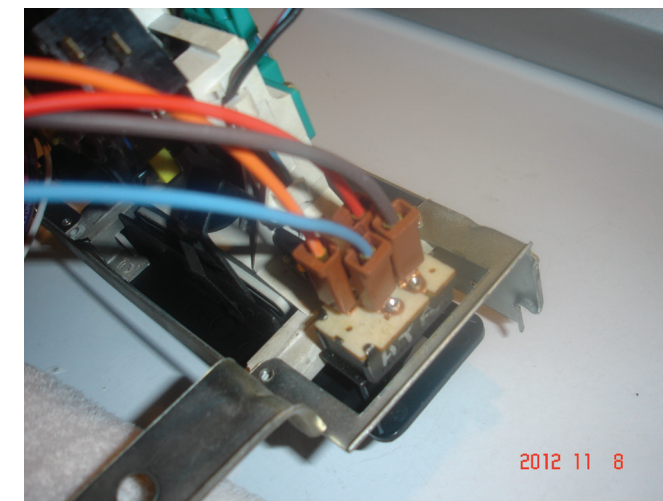
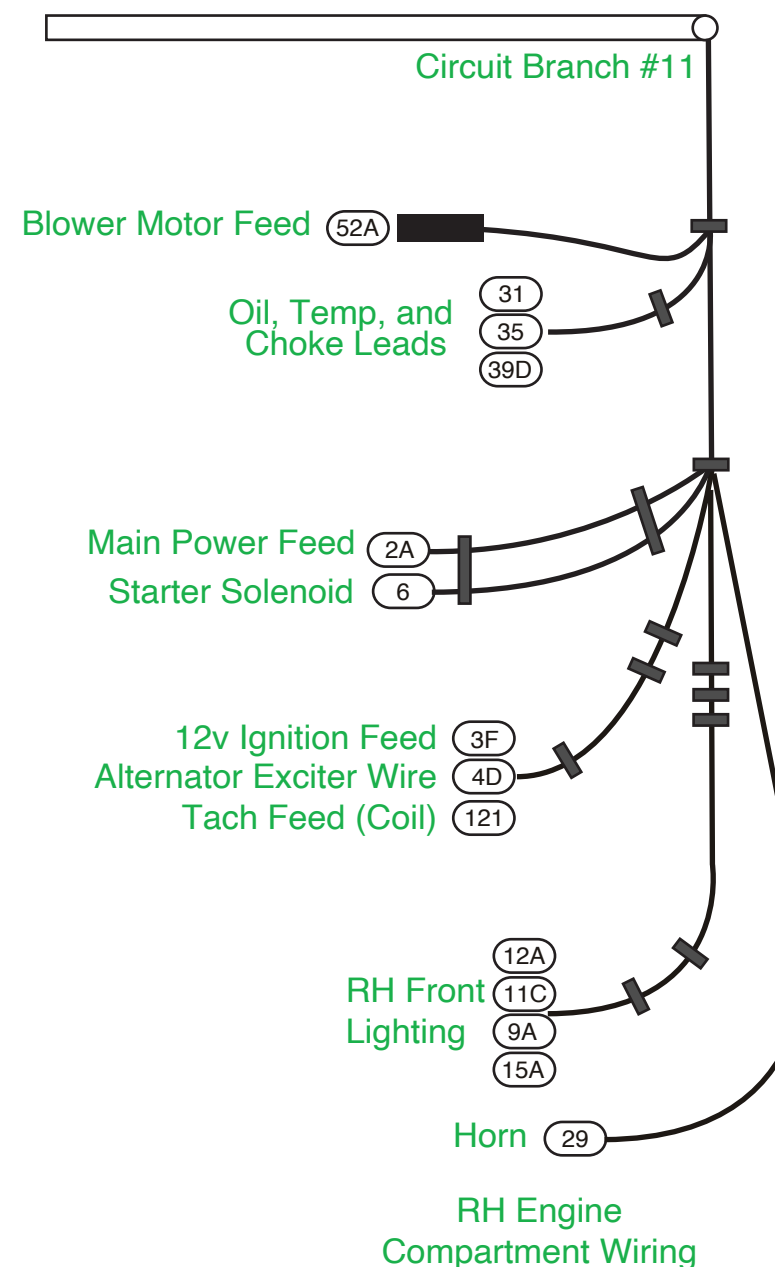

Photo "A"  
1973 thru early 1978  
(before serial number  
CA0001) heater blower  
switch connections  
(from page 6).

**American  
Autowire**

www.americanautowire.com 856-933-0801

PART # **510342**

DESCRIPTION:  
1973-79 Ford F100-350  
& 1978-79 Ford Bronco  
Classic Update Series Kit

92970164 Rev. 16.0 JDM 05/20/2024

AMERICAN AUTOWIRE DASH HARNESS CONNECTION

ORIGINAL TURN SIGNAL SWITCH WIRING

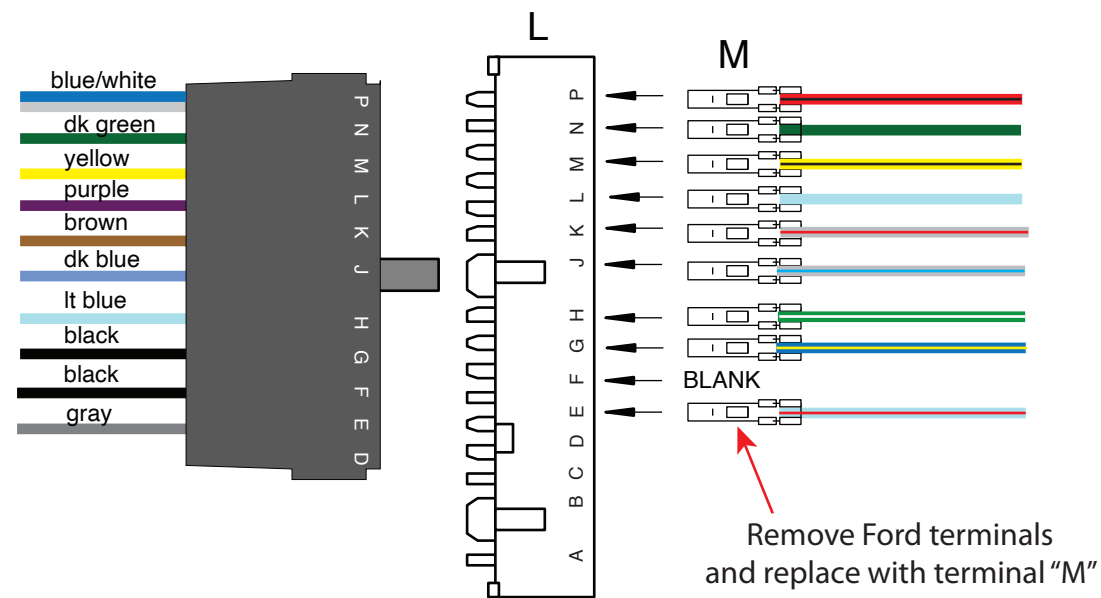

**DIAGRAM 'A' - AAW Turn Signal Switch Wires to Stock 1973-77 (all) and 1978-79 (w/speed control) Steering Columns.**

AMERICAN AUTOWIRE DASH HARNESS CONNECTION

ORIGINAL TURN SIGNAL SWITCH WIRING

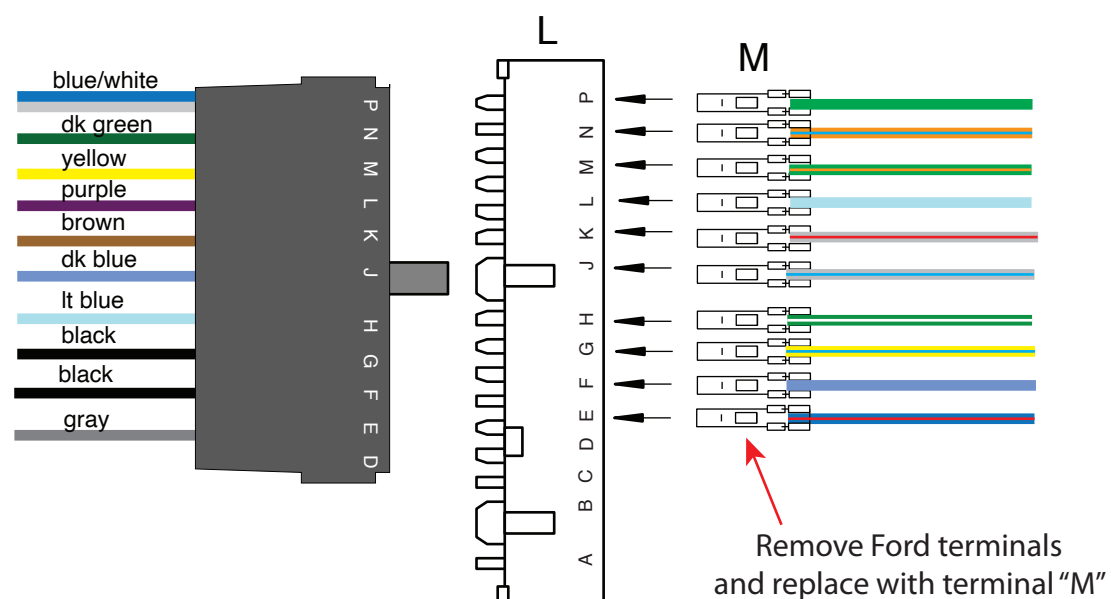

**DIAGRAM 'A' - AAW Turn Signal Switch Wires to Stock 1978-79 (w/o speed control) Steering Columns (optional Ford colors shown).**

**"Table A"**

AAW Turn Signal Switch wires to stock 1973-77 (all) and 1978-79 (with speed control) Ford Truck turn signal switch.

AAW Wire #	AAW Wire color	AAW Wire Printing	Ford Wire Color	Ford Wire Color - Optional
8C,D	Gray	Dash Lights	Lt. Blue with Red stripe.	Blue with Red stripe.
14A,B	Light Blue	Left Front Turn	Green with White stripe.	Green with White stripe.
15A,B	Dark Blue	Right Front Turn	White with Blue stripe.	White with Blue stripe.
16	Purple	Turn Switch Feed	Lt. Blue.	Lt. Blue.
17A,B	Blue & White	Brake Switch	Red with Black stripe.	Green.
18	Yellow	Left Rear Turn	Yellow with Black stripe.	Green with Orange stripe.
19	Dark Green	Right Rear Turn	Green.	Orange with Blue stripe.
27	Brown	Turn Sw - Hazard	White with Red stripe.	White with Red stripe.
28	Black	Horn Relay Ground	Blue with Yellow stripe.	Dark Blue.
28A	Black	Horn Relay Ground	Not applicable.	Not applicable.
N/A	N/A	N/A	Blue with Black stripe (Ford 151 wire).	Blue with Black stripe (Ford 151 wire).

**NOTE:** For these vehicles, the stock Ford steering column horn button switched ground to a horn relay, just as the AAW system does. Therefore the 28A wire is not necessary and will not be used. The Blue with Black stripe 151 wire, on your Ford schematic, is for your stock Speed Control which is not supported in this AAW kit.

**"Table A"**

AAW Turn Signal Switch wires to stock 1978-79 (without speed control) Ford Truck turn signal switch.

AAW Wire #	AAW Wire color	AAW Wire Printing	Ford Wire Color	Ford Wire Color - Optional
8C,D	Gray	Dash Lights	Lt. Blue with Red stripe.	Blue with Red stripe.
14A,B	Light Blue	Left Front Turn	Green with White stripe.	Green with White stripe.
15A,B	Dark Blue	Right Front Turn	White with Blue stripe.	White with Blue stripe.
16	Purple	Turn Switch Feed	Lt. Blue.	Lt. Blue.
17A,B	Blue & White	Brake Switch	Red with Black stripe.	Green.
18	Yellow	Left Rear Turn	Yellow with Black stripe	Green with Orange stripe
19	Dark Green	Right Rear Turn	Green.	Orange with Blue stripe.
27	Brown	Turn Sw - Hazard	White with Red stripe.	White with Red stripe.
28	Black	Horn Relay Ground	Yellow.	Yellow with Blue stripe.
28A	Black	Horn Relay Ground	Blue with Yellow stripe.	Dark Blue.

**NOTE:** For these vehicles, the stock Ford steering column horn button switched 12v power directly to the horns. This AAW kit switches ground through the steering column horn button, which grounds a horn relay that switches the power to the horns. Therefore the 28A wire is needed, and will need to be used in this application. Please attach the ring terminal on this wire to a good known chassis ground.

Wires indicated as having a "stripe" on them, may have a stripe, hashes or dots, to indicate the secondary color.



**American Autowire**

www.americanautowire.com 856-933-0801

PART # **510342**  
 DESCRIPTION:  
 1973-79 Ford F100-350  
 & 1978-79 Ford Bronco  
 Classic Update Series Kit



## LH and RH engine bay grommet installation details:

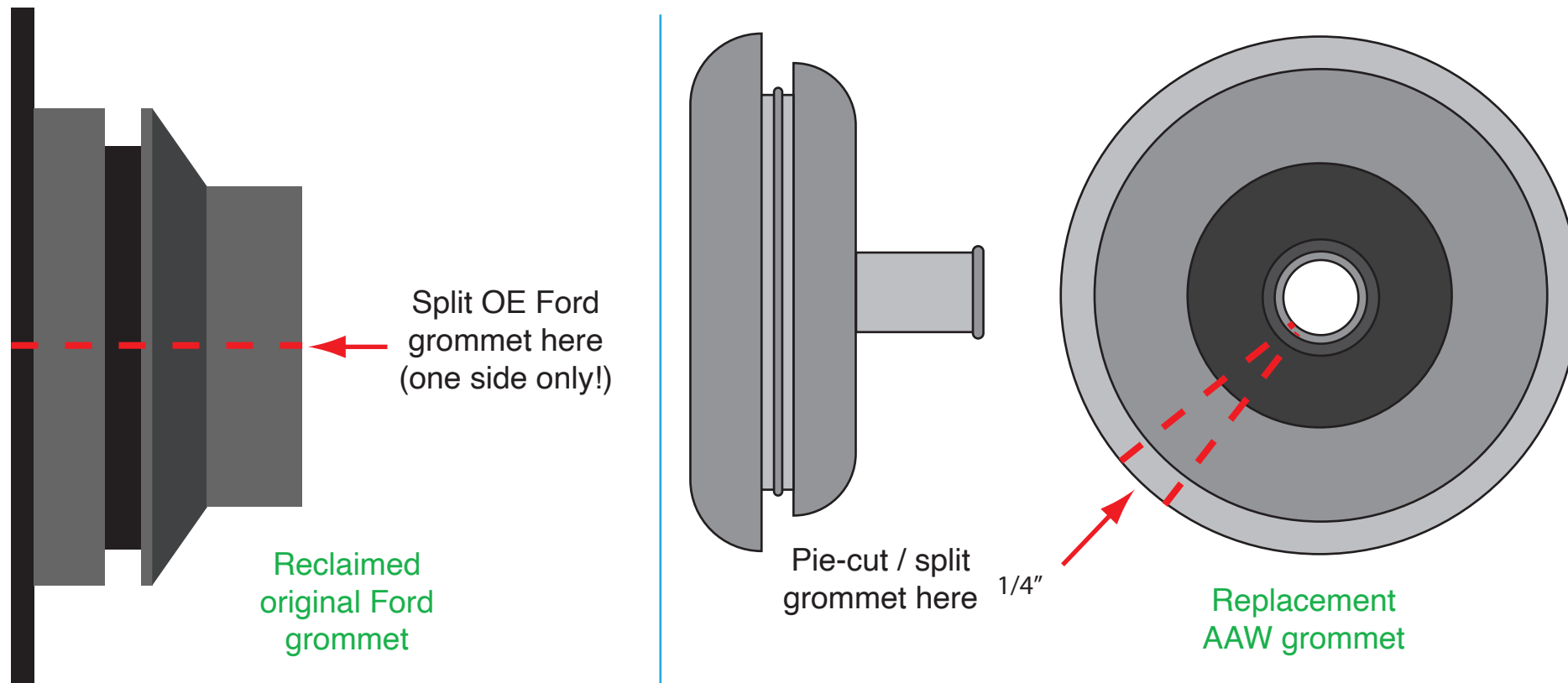

**NOTE:** Before you route the Dash Harness through the Firewall, follow these instructions:

1. We recommend that you re-use the original Ford Grommets that are located on the LH and RH branch of the original wiring harness and were seated in the firewall. Split the grommet by cutting it on one side only, remove it from the original harness and fit it over the new engine bay wiring (circuit branch #'s 11 & 12).
2. If the original grommets are not salvageable, we have provided a new set of grommets. These grommet can be found in 510352 "Clamp, Grommet, and Parts Kit". You will have to split and pie cut the new grommets as shown here. Attach them to the LH and RH engine bay wiring (circuit branch #'s 11 & 12).
3. With the grommets installed on the Engine Bay Wiring, route each branch through their respective firewall opening and seat the grommet into the firewall. Be sure to orient the grommet in the firewall opening so the split in the grommet is facing down toward the ground.
4. Complete the terminations of the engine bay wiring. Details regarding final assembly of the engine bay wiring can be found on the following pages:  
 RH Engine Bay Wiring (circuit branch # 11): Page 10  
 LH Engine Bay Wiring (circuit branch #12): Page 12
5. After all terminations are completed, the openings in the grommets should be filled with silicone sealer to ensure a weather-tight seal.

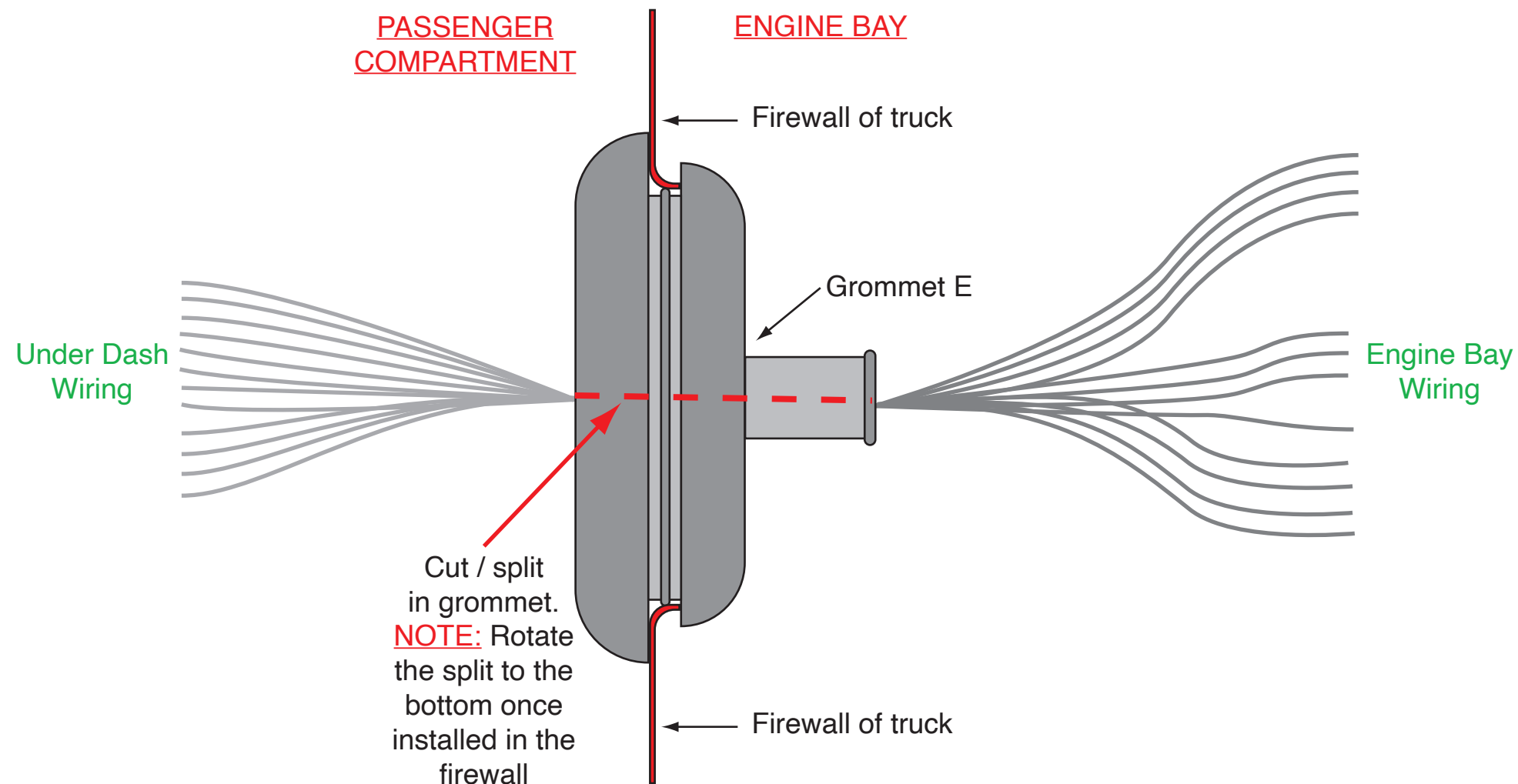

www.americanautowire.com 856-933-0801

PART # **510342**  
 DESCRIPTION:  
 1973-79 Ford F100-350  
 & 1978-79 Ford Bronco  
 Classic Update Series Kit

92970164 Rev. 16.0 JDM 05/20/2024

# Figure "A", Branch #11 Passenger's Side Location

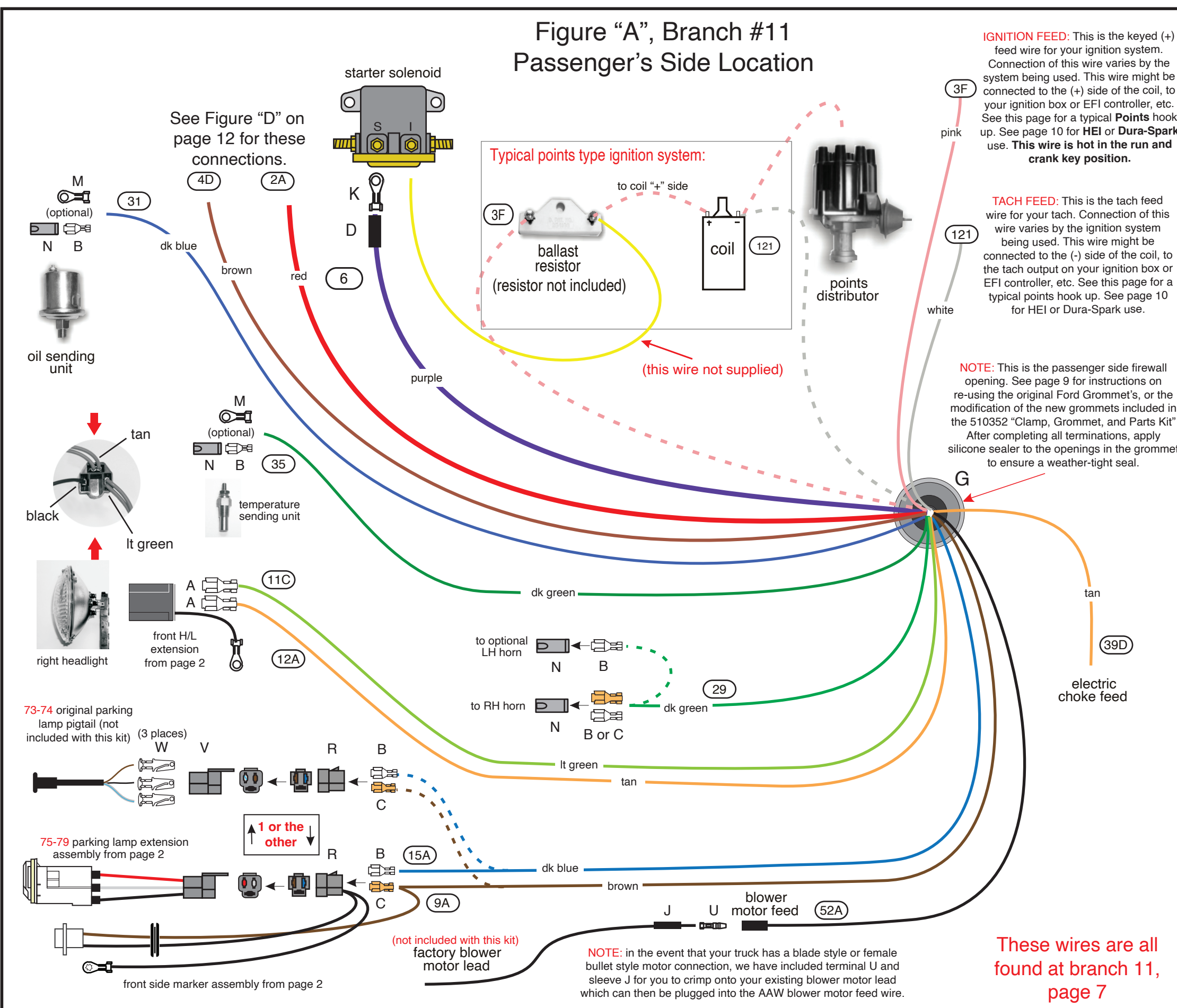

**IGNITION FEED:** This is the keyed (+) feed wire for your ignition system. Connection of this wire varies by the system being used. This wire might be connected to the (+) side of the coil, to your ignition box or EFI controller, etc. See this page for a typical **Points** hook up. See page 10 for **HEI** or **Dura-Spark** use. **This wire is hot in the run and crank key position.**

**TACH FEED:** This is the tach feed wire for your tach. Connection of this wire varies by the ignition system being used. This wire might be connected to the (-) side of the coil, to the tach output on your ignition box or EFI controller, etc. See this page for a typical points hook up. See page 10 for HEI or Dura-Spark use.

**NOTE:** This is the passenger side firewall opening. See page 9 for instructions on re-using the original Ford Grommet's, or the modification of the new grommets included in the 510352 "Clamp, Grommet, and Parts Kit" After completing all terminations, apply silicone sealer to the openings in the grommet to ensure a weather-tight seal.

**These wires are all found at branch 11, page 7**

**NOTE:** The terminals and connectors listed on this page and denoted with **UPPER CASE LETTERS** are to help you complete the various connections to your lamps, engine connections, switches, horn, etc. They can all be found in your loose piece clamp, grommet, and parts kit, P/N 510352.

The identifications, colors, and functions for all of the wires listed in "Figure A" on this page can be found on page 7, branch 11 of this main instruction set (9270164). AAW suggests and recommends using pages 7, 10, 11 and 12 to complete the installation of the RH forward lamp, turn, various engine functions, alternator ignition, starter solenoid, and blower motor connections.

This AAW kit is engineered to work with a stock heater system and most aftermarket manufacturer's heating and air conditioning systems. As such, we have provided a keyed 12-volt feed to use as the "OFF / ON" (AAW brown 50 wire) power source for whatever system you choose to purchase. The manufacturer will supply you with a harness for their system and instructions on how to connect it. In the event you are utilizing a stock heater system in your truck, we have also provided wires that will run from your heater switch to your heater resistor and then on to your blower motor. See the photo of the switch connections on page 7. We have also included a 1978-79 heater switch extension in the event that you are working on one of those trucks. See the instructions on page 6 that will explain how to plug that extension onto your dash/main harness.



www.americanautowire.com 856-933-0801

PART # **510342**  
 DESCRIPTION:  
**1973-79 Ford F100-350 & 1978-79 Ford Bronco Classic Update Series Kit**  
 92970164 Rev. 16.0 JDM 05/20/2024

RH headlamp, RH parking lamp, engine, main power, alternator ignition, and starter solenoid connections.



**American  
Autowire**

www.americanautowire.com 856-933-0801

Engine harness  
installation:

**(common ignition  
system examples)**

**Generic HEI Ignition system wiring:**

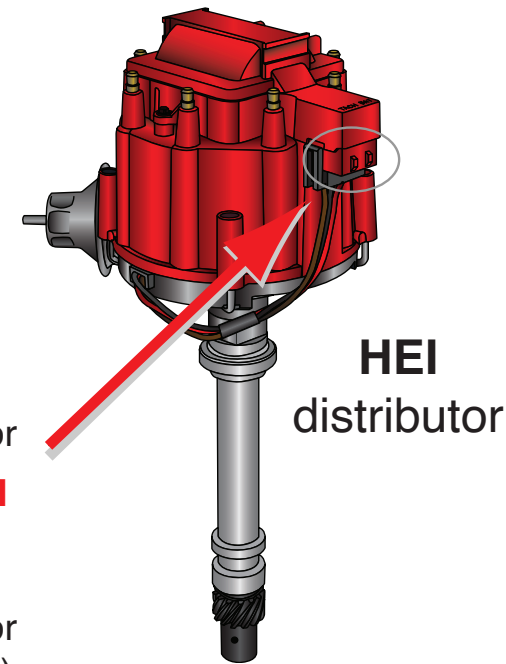
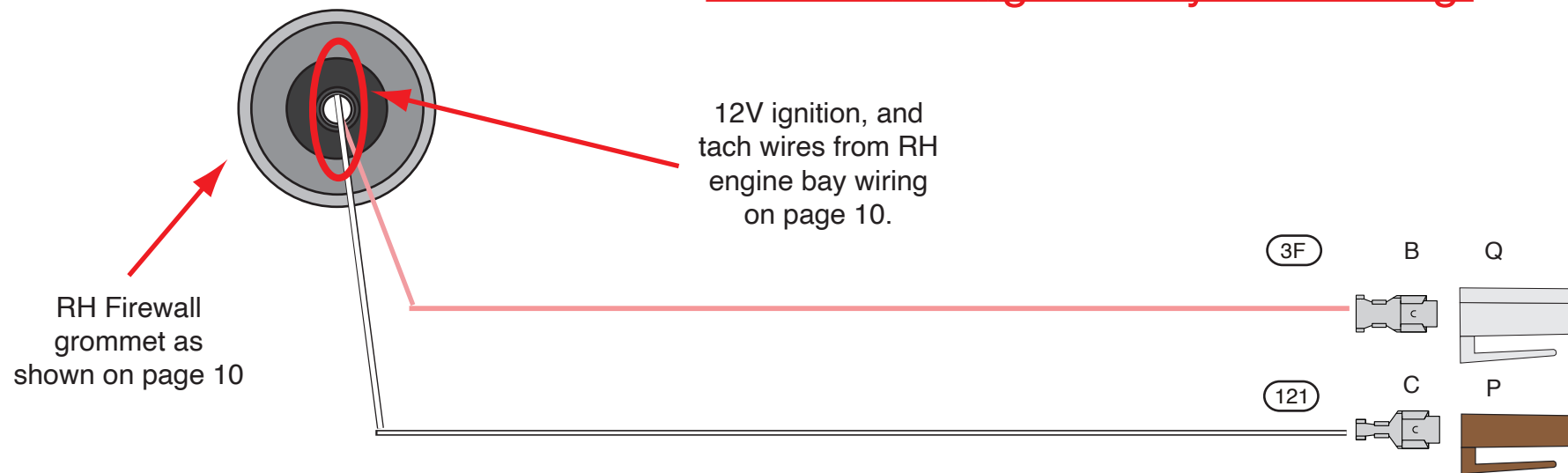

to **BAT**  
location  
on HEI  
distributor

to **TACH**  
location  
on HEI  
distributor  
(optional)

**Generic Ford Dura-Spark Ignition system wiring:**

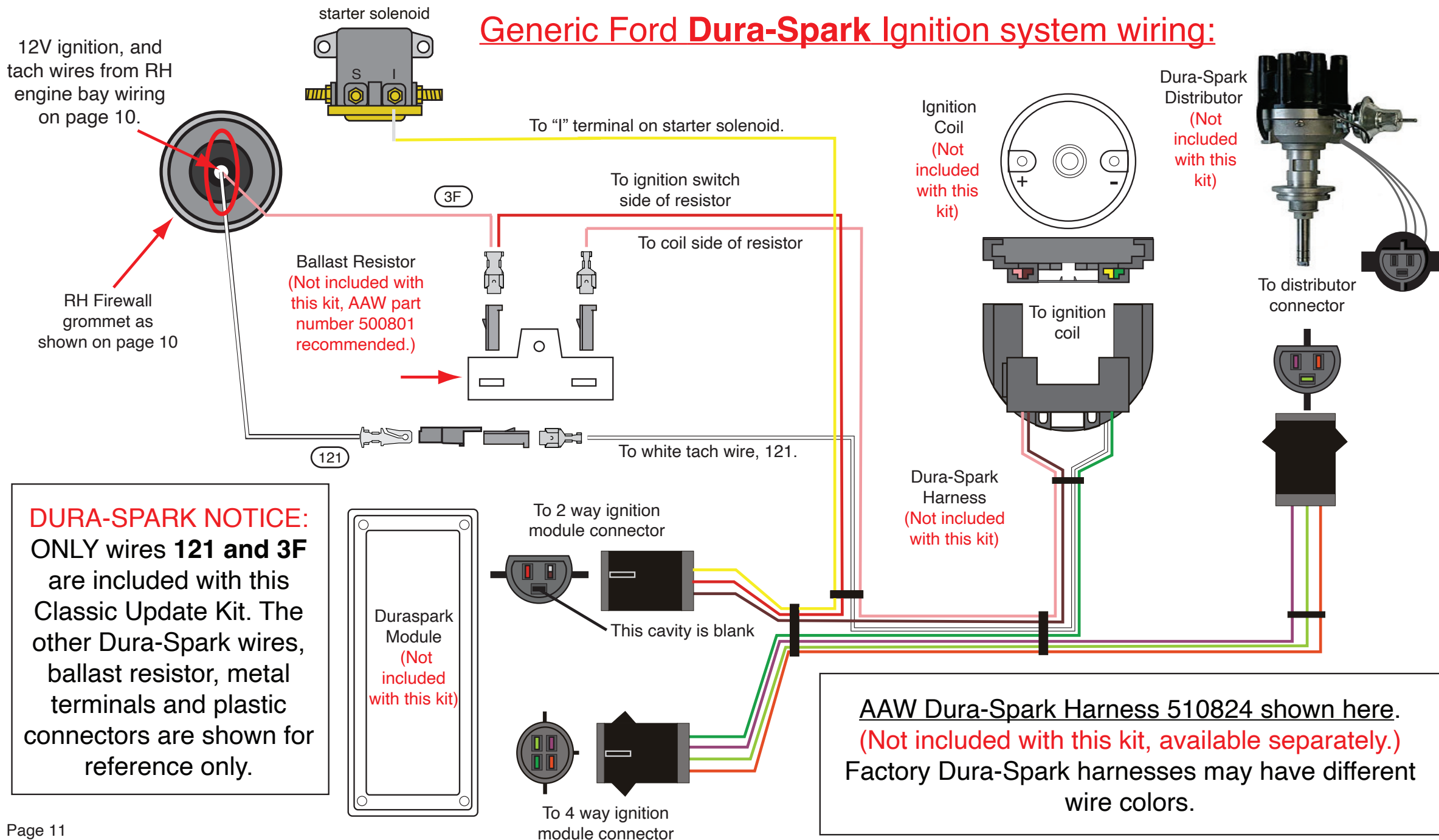

**DURA-SPARK NOTICE:**  
ONLY wires 121 and 3F  
are included with this  
Classic Update Kit. The  
other Dura-Spark wires,  
ballast resistor, metal  
terminals and plastic  
connectors are shown for  
reference only.

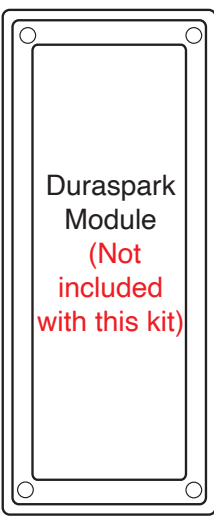

**AAW Dura-Spark Harness 510824 shown here.  
(Not included with this kit, available separately.)  
Factory Dura-Spark harnesses may have different  
wire colors.**

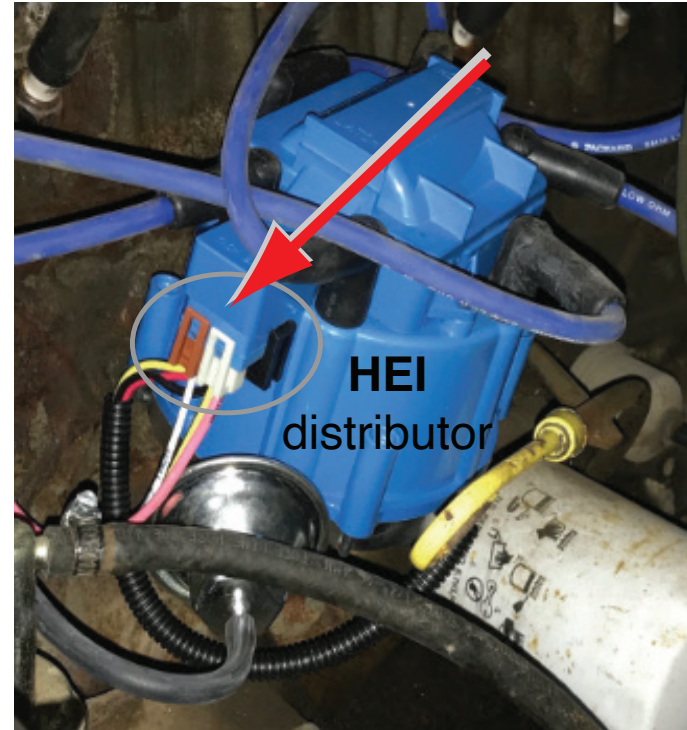

PART # **510342**

DESCRIPTION:  
**1973-79 Ford F100-350  
& 1978-79 Ford Bronco  
Classic Update Series Kit**

92970164 Rev. 16.0 JDM 05/20/2024

**Figure "C", Branch #12**  
Driver's Side Location

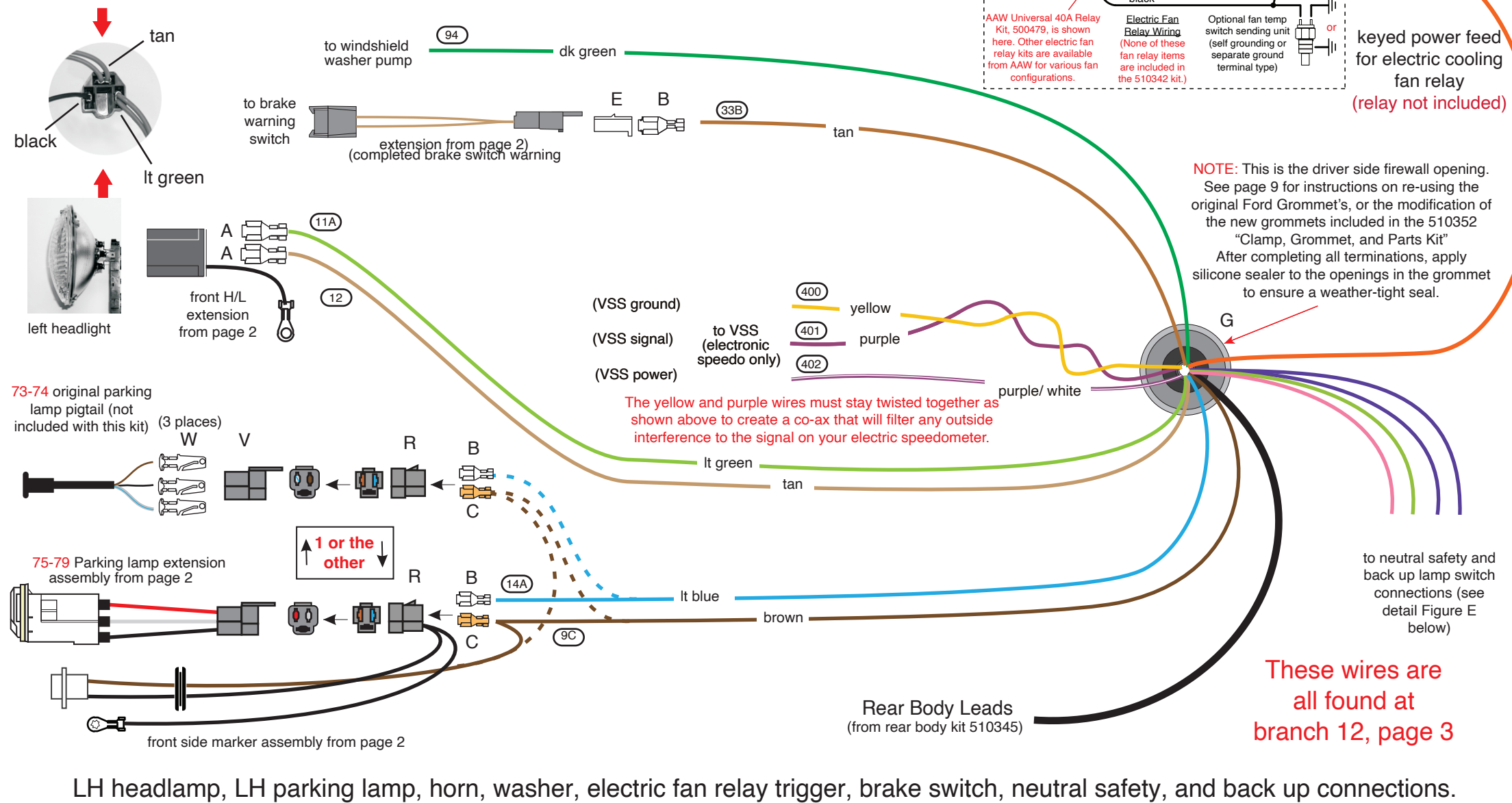

**NOTE:** The terminals and connectors listed on this page and denoted with **UPPER CASE LETTERS** are to help you complete the various connections to your lamps, brake warning switch, electric fan, back up and neutral safety switch, washer pump, etc. They can all be found in your loose piece clamp, grommet, and parts kit, P/N 510352. No terminals are provided for the neutral safety or back up switch connections.

The identifications, colors, and functions for all of the wires listed in "Figures C, D, and E" on this page can be found on page 3, branch 12, and page 7, branch 11 of this main instruction set (92970164). AAW suggests and recommends using pages 3, 7, and 12 to complete the installation of the LH forward lamp, turn, brake warning switch, electric fan, neutral safety and back up switch, washer pump, alternator exciter and power connections, and the main power feed.

AAW kits are all engineered to be used in conjunction with a high output, later model internally regulated, or one wire alternator. We do not suggest or support the use of a stock low amperage alternator as they do not supply sufficient current to recharge the battery in a highly modified truck such as this kit was designed for. AAW suggests a Ford Gen III, a GM "SI", or a 1 wire type alternator as good choices to use. An adapter to complete the connection to the Ford Gen III style alternator (AAW p/n 500802) may be purchased separately. Contact AAW for your needs.

**Figure "D"**  
Main Power and Alternator Wiring

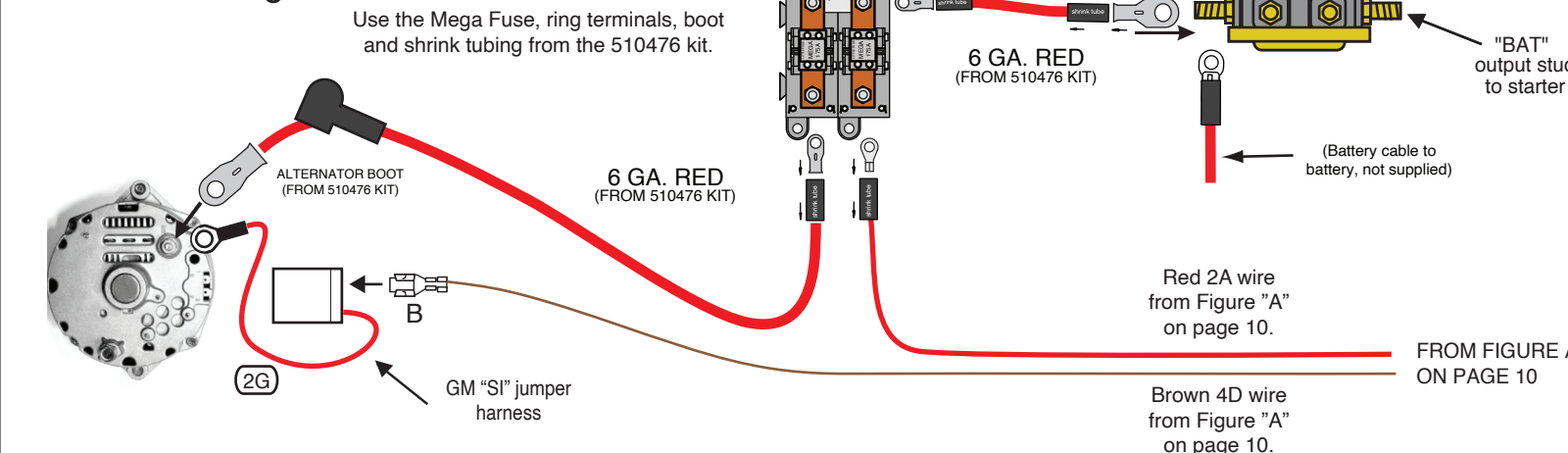

**Figure "E"**

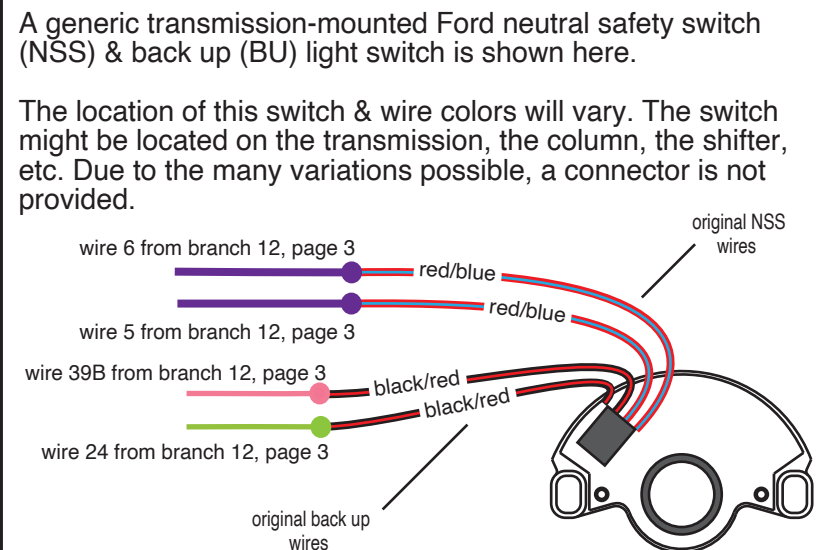

www.americanautowire.com 856-933-0801

PART # **510342**

DESCRIPTION:  
**1973-79 Ford F100-350**  
**& 1978-79 Ford Bronco**  
**Classic Update Series Kit**

92970164 Rev. 16.0 JDM 05/20/2024

# FUSE AND FLASHER LOCATIONS

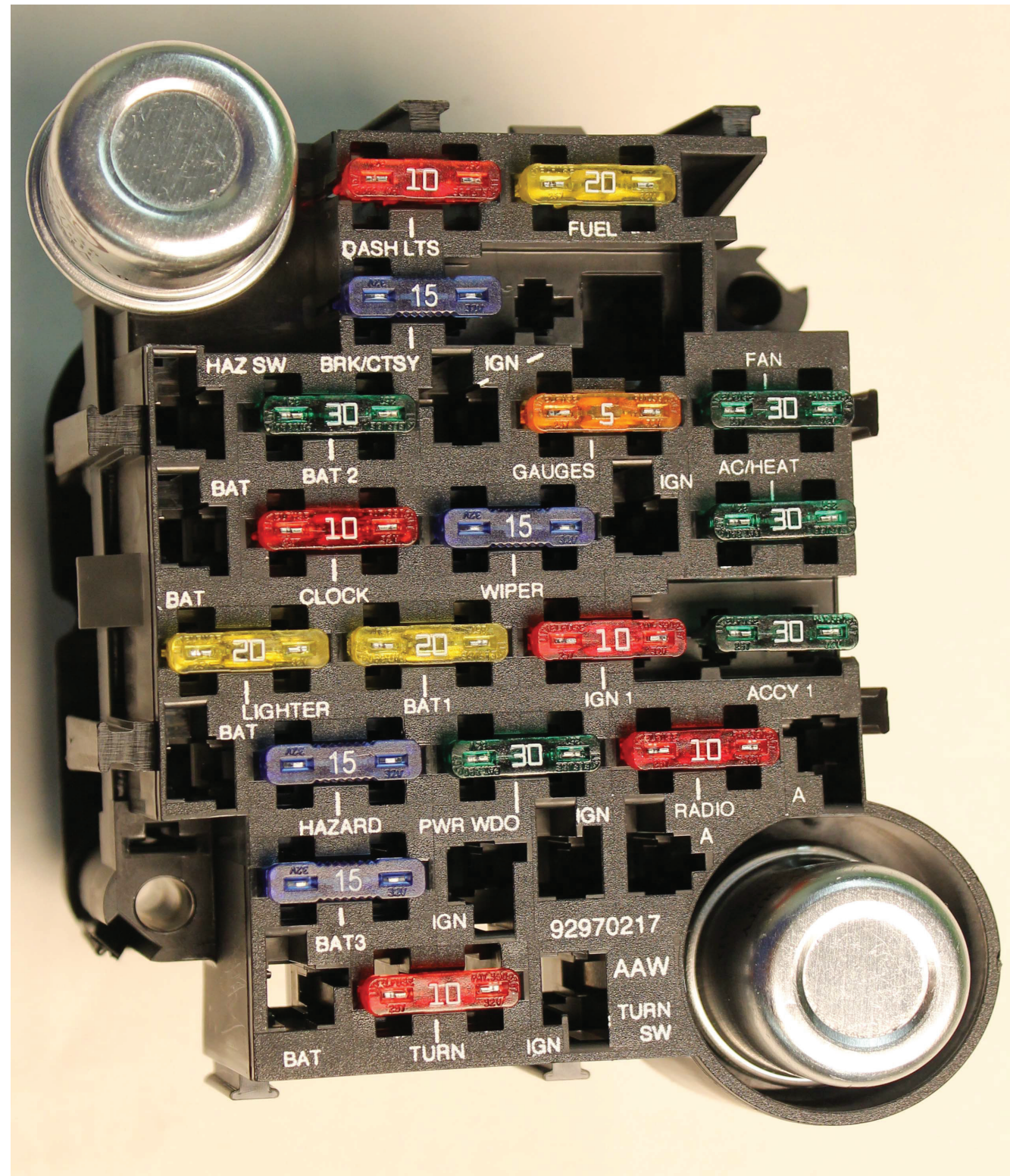

NOTE: Above, you will find a photograph of the completed fusebox assembly depicting the proper location for the installation of each fuse and the two flasher cans.



**American  
Autowire**

www.americanautowire.com 856-933-0801

PART # **510342**

DESCRIPTION:  
1973-79 Ford F100-350  
& 1978-79 Ford Bronco  
Classic Update Series Kit

92970164 Rev. 16.0 JDM 05/20/2024

This page intentionally left blank



**American  
Autowire**

[www.americanautowire.com](http://www.americanautowire.com) 856-933-0801

PART # **510342**

DESCRIPTION:  
1973-79 Ford F100-350  
& 1978-79 Ford Bronco  
Classic Update Series Kit

92970164 Rev. 16.0 JDM 05/20/2024